

temperature (which lowers the vapor pressure). The temperature at which the water vapor in a given sample of air becomes saturated is called the dew point. Measuring the dew point temperature is the most accurate method determining the relative humidity. This is usually done by cooling a metal container with a bright shiny surface and recording the temperature when the surface becomes clouded with condensation.

The rate of evaporation of water also depends upon the relative humidity. Evaporation is the most rapid when the relative humidity is low. As the relative humidity increases, the evaporation rate decreases. If the relative humidity increases to 100%, no further evaporation takes place. This is the principle by which the sling psychrometer works. Energy, in the form of heat, is removed from the wicking around the thermometer bulb as the water evaporates. Therefore, when the relative humidity is low, the evaporation rate is high, and the thermometer indicates a lower temperature. When the relative humidity is high, the evaporation rate is low and the thermometer indicates a lesser decrease in temperature.

Anyone who has experienced a hot muggy day when the relative humidity was very high knows that it is more uncomfortable than the same temperature day when the relative humidity is low. This has to do with the efficiency of your body's main cooling mechanism - evaporation of perspiration. On days when the relative humidity is high, the evaporation rate is lower and the resultant cooling is less, on days when the relative humidity is low, the evaporation rate is high and the resultant cooling is higher.

The relationship between the evaporation rate (cooling) and relative humidity has been well documented and is usually presented in a graphical form. These graphs are referred to as "psychrometric charts".

One such chart is presented here for your use. Temperatures on this chart are in degrees Celsius.

The chart may look a little strange at first glance. This is because it is really a couple of charts placed one on top of the other. Not only does it tell you the relative humidity given the wet bulb and dry bulb temperatures, but you can also determine the humidity ratio (weight of moisture to weight of dry air). The information contained in this chart is based on standard atmospheric pressure (29.921 inches of mercury).

For a little practice in reading this psychrometric chart, consider a dry bulb temperature of 25° C and a wet bulb temperature of 18° C.

First locate the dry bulb temperature on the bottom of the chart. Next locate the wet bulb temperature on the diagonal axis on the left side of the chart. The 18° line would be parallel to the 20° and lower by 2/5 of the interval between 15 and 20°. Follow each of the lines corresponding to these temperatures until you come to a point where they cross. To determine the relative humidity, estimate the distance between the curved lines labeled with the percent relative humidity, this intersection falls near 50% for this example.

To determine the humidity ratio, start from the intersection of the two temperature lines and move horizontally to the right until you come to the vertical axis labeled 'Humidity Ratio'. You should find that the humidity ratio is approximately 0.010 tons moisture per ton of dry air, for this example.

Time Allocation:

Ten minutes assembly is required for this product. Individual experiment times will vary depending on methods of instruction, but normally will not exceed one class period.

Feedback:

If you have a question, a comment, or a suggestion that would improve this product, you may call our toll free number.

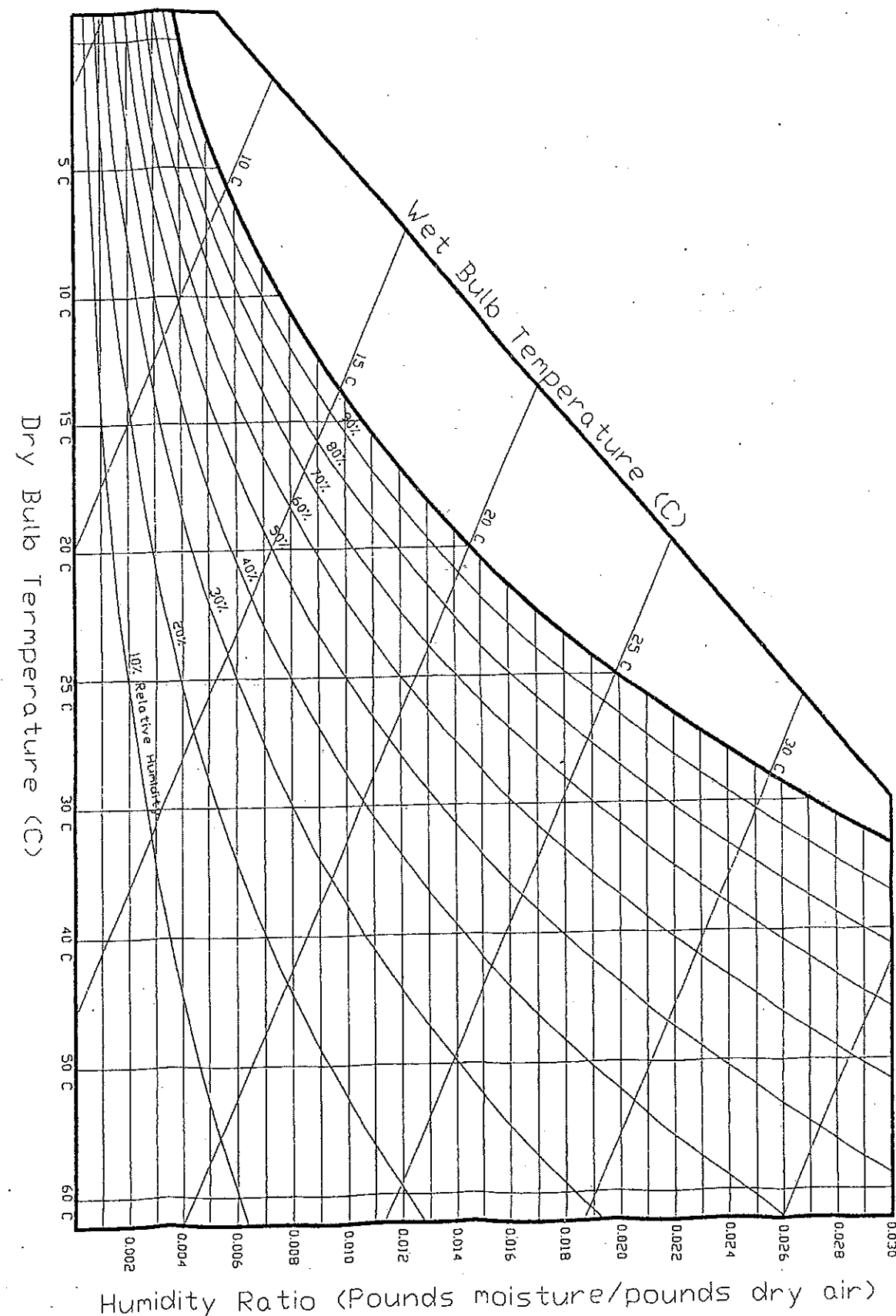

16220 Psychrometer, Student Kit

Purpose:

To provide an exercise in the measurement of relative humidity by using the "wet/dry bulb" method.

Contents:

- One (1) Handle
- Two (2) Rubber Bands
- One (1) Screw
- Two (2) Thermometers, **GLASS**
- One (1) Felt Wick
- One (1) Psychrometric Chart

Required: Standard Screwdriver

Assembly:

Assemble by placing the thermometers back to back on the handle as shown. Attach the wicking to one bulb and hold both thermometers in place with the rubber bands. **Check that the thermometer tubes are secure on the plastic back. They should not slide. Tampering with the mounting can make them fly off dangerously.**

To determine relative humidity, wet the wicking and **gently swing** both thermometers at a constant rate. After a period of time, record the two readings and find the difference in temperature between the wet and dry bulb thermometers. **Gently swing** the pair again and check to see if the spread is the same. The lowest reading will be on the wet bulb. Then with the aid of standard tables or graphs from the text, find the relative humidity using the temperature difference.

Discussion:

Air is a mixture of gases consisting of approximately 78% nitrogen, 21% oxygen, and small amounts of carbon dioxide, water vapor, and other gases. The ratio of water vapor mass per unit volume of air is known as Absolute Humidity and is similar to measuring the "density" of water vapor. Relative humidity, on the other hand, is a normalized scale that represents saturated water vapor as 100% RH (relative humidity) and an absence of water vapor as 0% RH. The relative humidity can be calculated by comparing the partial pressure of water vapor to the vapor pressure of water at the same temperature.

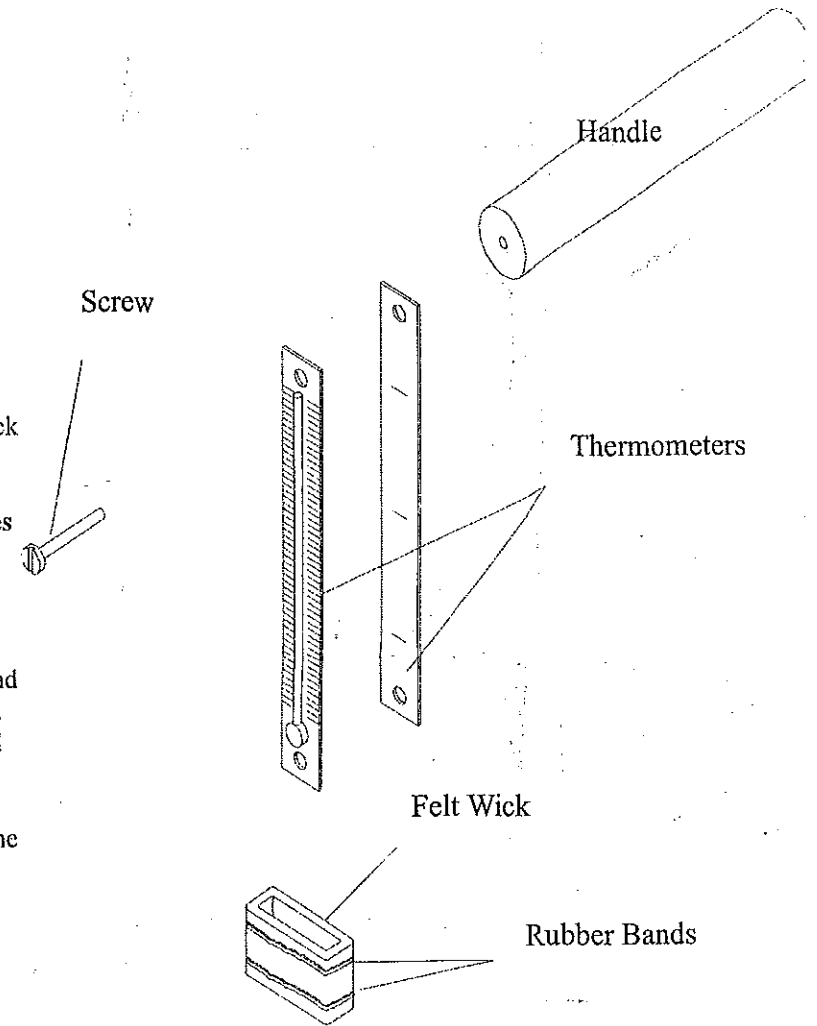

$$RH(\%) = 100 * (PP_{H_2O}/VP)$$

Where:

- RH is the relative humidity in percent
- PP is the partial pressure of the water vapor
- VP is the vapor pressure

As you can see from the above relationship, the water vapor in the air is saturated (relative humidity of 100%) when its partial pressure equals the vapor pressure at that air temperature. Saturation of the water vapor can be brought about by either increasing the water vapor content or lowering the