

**Homework Problem H16.A**

**Given:** An angled water gate is supported by a pin joint at A and a roller support at B. The gate has a dimension into the page of  $b$ . The water has a density of  $\rho$ , and the weight of the gate is negligible compared to the weight of the water that it supports.

**Find:** Determine the reaction force on the gate at support B.

Leave your answer in terms of, at most:  $d$ ,  $b$ ,  $g$  and  $\rho$ .

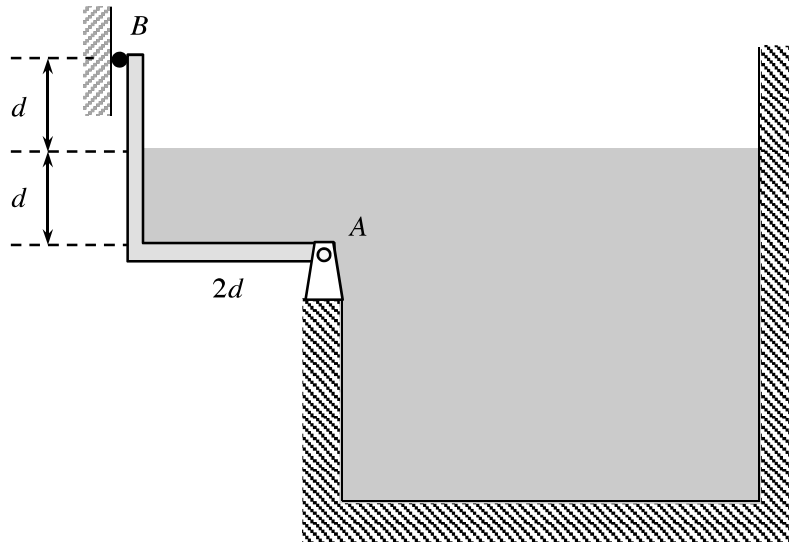

**Homework Problem H16.B**

**Given:** A water gate is supported by a pin joint at A and a cable-pulley system at B. A counterweight C is attached to the end of the cable. The gate has a dimension into the page of  $b$ . The water has a density of  $\rho$ , and the weight of the gate is negligible compared to the weight of the water that it supports.

**Find:** Determine the weight of C required to hold the gate in equilibrium.

Leave your answer in terms of, at most:  $d$ ,  $b$ ,  $g$  and  $\rho$ .

