

Problem 11.1 (10 points)

For the given stress element,

- Calculate the three principal stresses, the absolute maximum shear stress $\tau_{max,abs}$ and the von-Mises stress.
- If the material is ductile and the yield stress is 140 MPa, determine the factor of safety using the maximum shear stress theory and the maximum distortion energy theory.
- If the material is brittle, the ultimate tensile stress is 156 MPa the ultimate compression stress is 223 MPa determine the factor of safety using the maximum normal stress theory and Mohr's failure criterion.

Use: $\sigma_x = -15\text{MPa}$, $\sigma_y = -25\text{MPa}$, and $\tau_{xy} = +45\text{ MPa}$

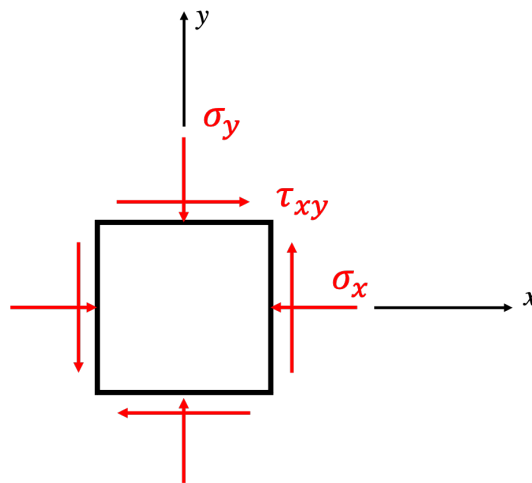

Figure 1

Problem 11.2 (10 points): The structure shown in Fig 2 (a) is composed of a steel cable AB and a wood member BC. Member BC is made of two segments and a pin scarf joint as shown in Fig 2 (c). The structure is acted upon by a load P at B, as shown. The pin and steel cable are both circular in cross section, of diameter d , and are made of steel with following properties,

$$\tau_{\text{fail,pin}} = 0.2 \sigma_{\text{yield,steel}}$$

$$FS_{\text{cable}} = 2, \sigma_{\text{yield,steel}} = 400 \text{ MPa}, d = 1 \text{ cm}$$

- Determine axial loads in cable AB and member BC as a result of applied load P . Are the loads tensile or compressive?
- Using a free body diagram of the structural segment BEF, see Fig 2 (b), determine the tangential components of stress on the loaded cross section EF of the pin. Notice that the tangential load is carried only by the cross section of the pin whereas the compressive normal load is shared by the member BC and the pin.
- Determine the maximum allowable load P such that the structure does not fail. You need to consider failure for both pin and cable.

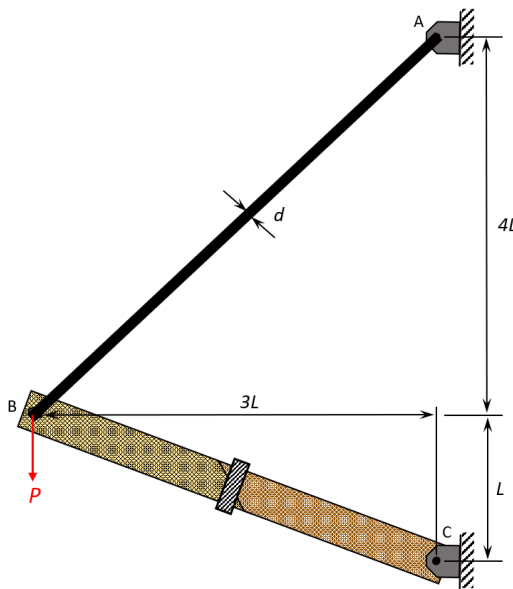

Fig. 2 (a)

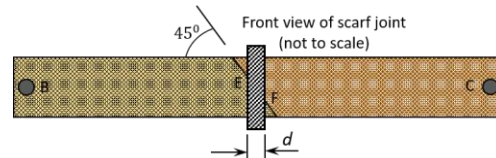

Fig. 2 (b)

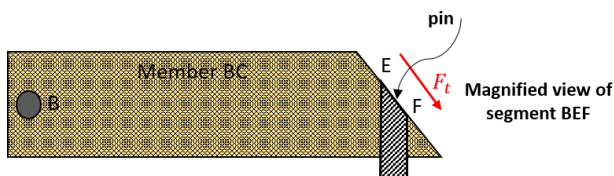

Fig. 2 (c)

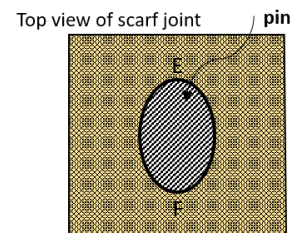

Fig. 2 (d)

Problem 11.3 (10 points)

A horizontal rigid bar DCB is supported by a very slender column AC and is subjected to a uniformly distributed load q . The column AC has a Young's modulus E and a rectangular cross section as is shown. Consider supports A and C to act as pinned-pinned when buckling in x-y plane and fixed-fixed when buckling in y-z plane. Determine the maximum distributed load q can be applied without buckling. Use: $L = 3 \text{ m}$, $b = 10 \text{ mm}$, $h = 20 \text{ mm}$, $E = 150 \text{ GPa}$.

Note: due to the boundary conditions at A and C, you must check buckling on both planes: x-y and y-z.

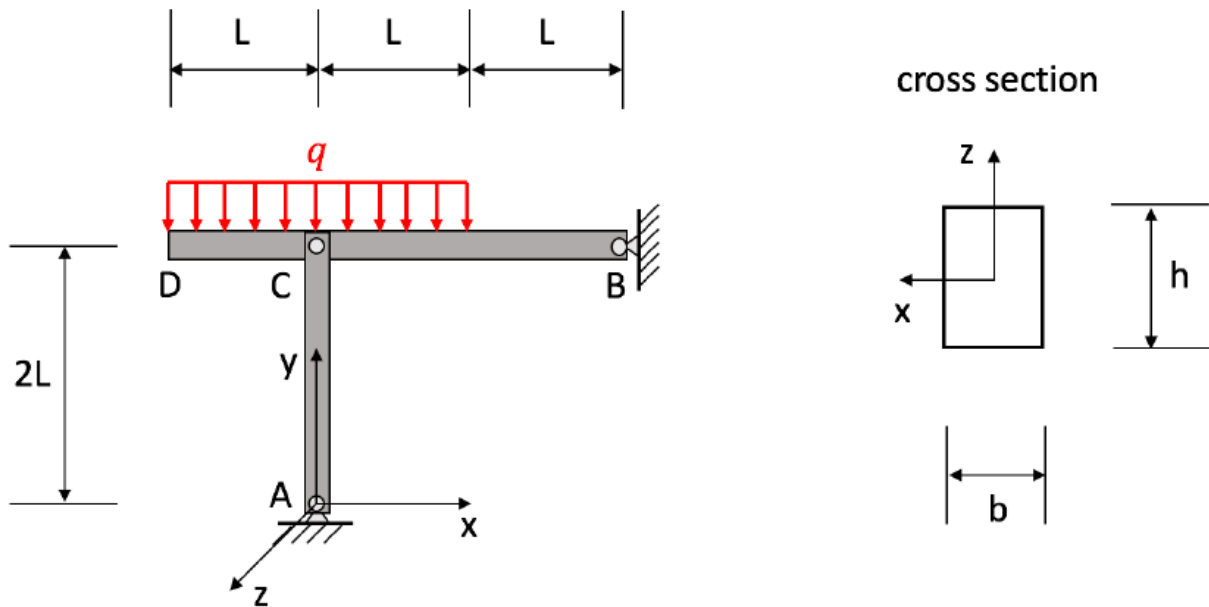

Figure 3

Problem 11.4 (5 points)

Cylindrical columns A, B, C and D shown below. A compressive axial load P is applied to each column. Use the following properties for the columns:

- a) Young's Modulus: E , radius: R , length: L
- b) Young's Modulus: $4E$, radius: $R/2$, length: L
- c) Young's Modulus: $4E$, radius: $R/2$, length: L
- d) Young's Modulus: $4E$, radius: R , length: L

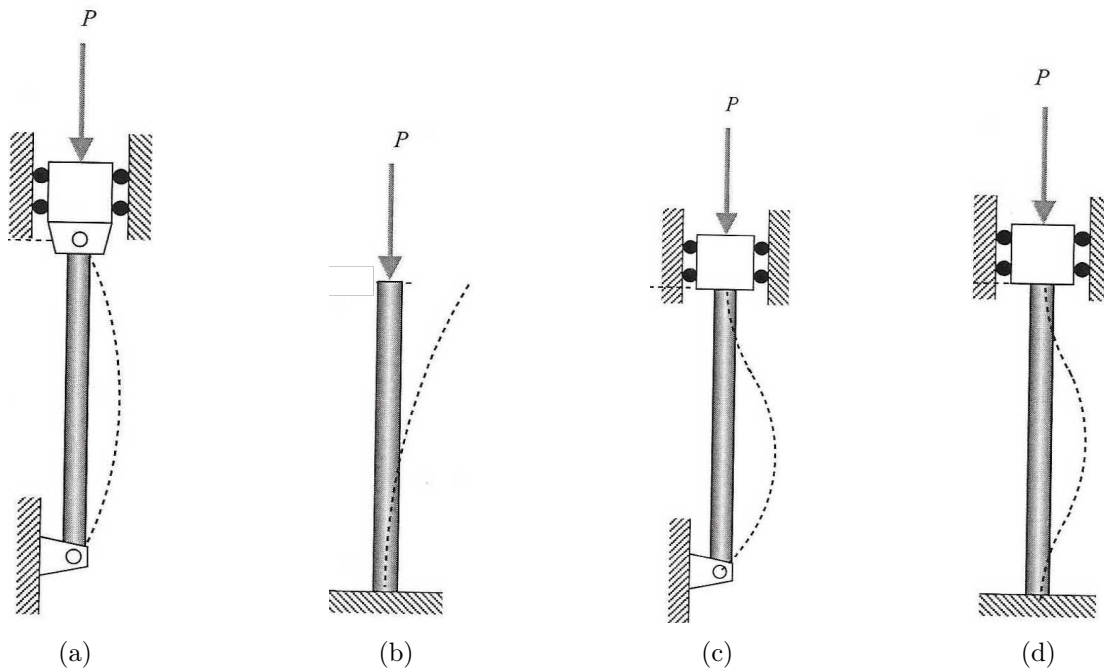

Figure 4

The critical Euler's buckling loads $P_{cr}^{(a)}$, $P_{cr}^{(b)}$, $P_{cr}^{(c)}$, $P_{cr}^{(d)}$ columns A, B, C, and D, respectively, are such that:

- 1. $P_{cr}^{(a)} = P_{cr}^{(b)} > P_{cr}^{(d)} = P_{cr}^{(c)}$
- 2. $P_{cr}^{(b)} = P_{cr}^{(c)} > P_{cr}^{(d)} > P_{cr}^{(a)}$
- 3. $P_{cr}^{(a)} > P_{cr}^{(d)} > P_{cr}^{(b)} = P_{cr}^{(c)}$
- 4. $P_{cr}^{(c)} > P_{cr}^{(d)} > P_{cr}^{(a)} = P_{cr}^{(b)}$
- 5. None of the above