

Problem 5.1

A composite shaft is made up of tubular elements (2) and (3), and a core (1). All elements are attached to a fixed wall at B and to a rigid connector at end C. The material making up elements (1), (2), and (3) have shear moduli of $G_1 = G$, $G_2 = 2G$ and $G_3 = G$, respectively. A torque T_0 is applied to connector C.

- Determine the torques in the three elements and the angle of rotation of connector C.
- Make an accurate sketch of the shear strain and shear stress distributions on a cross section of the shaft on the axes provided below for both the strain and stress distribution plots. Clearly indicate the slopes of the distribution curves.
- Show the components of stress on stress elements at points "a" and "b" on the shaft.

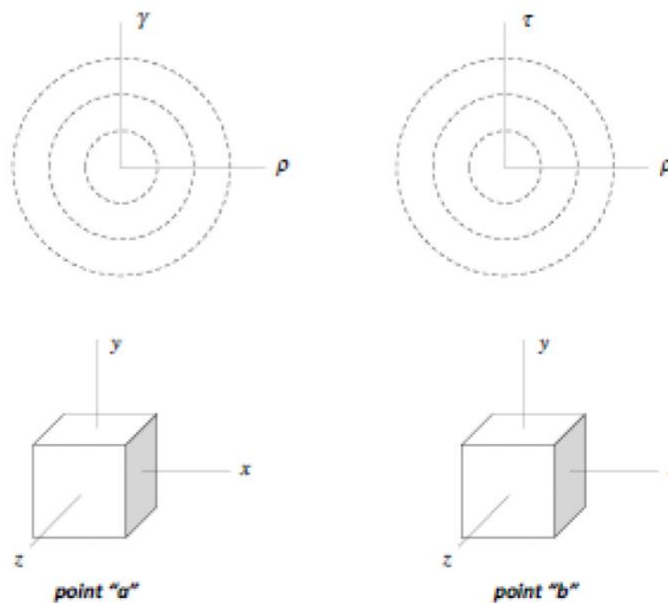
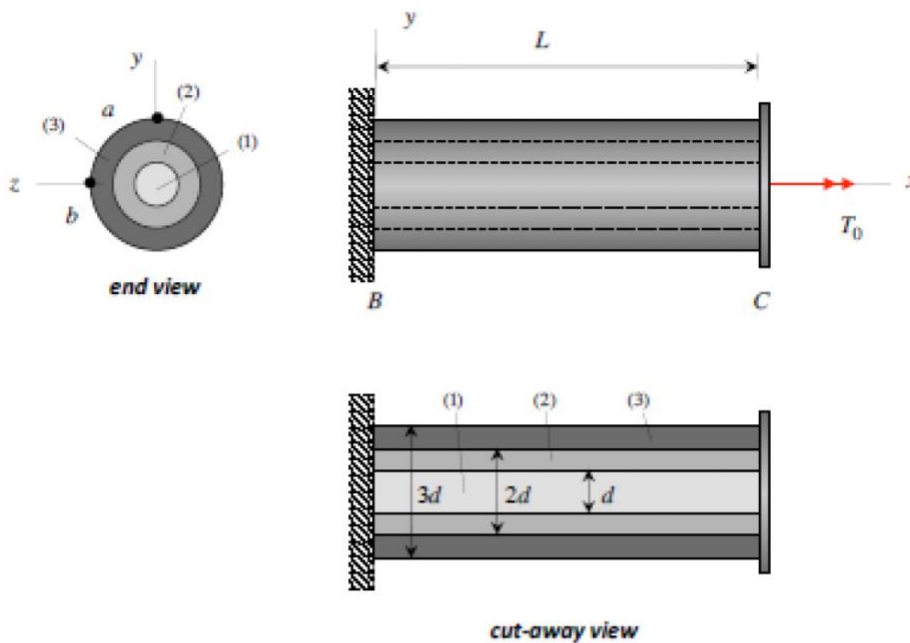

Problem 5.2 (10 points)

A beam is supported by a pin at A and a roller at D. It is subjected to a concentrated load P at C. The cross-section of the beam is shown below.

- (a) Determine the centroid of the given cross-section.
- (b) Determine the second moment of area of the cross-section.
- (c) Determine the shear stress at the centroid of the cross-section at B.
- (d) Determine the flexural stress at point M on the cross-section at B.

Use: $t=0.04\text{ m}$, $b=0.07\text{ m}$, $h=0.08\text{ m}$, $L=1\text{ m}$, $P=30\text{ N}$.

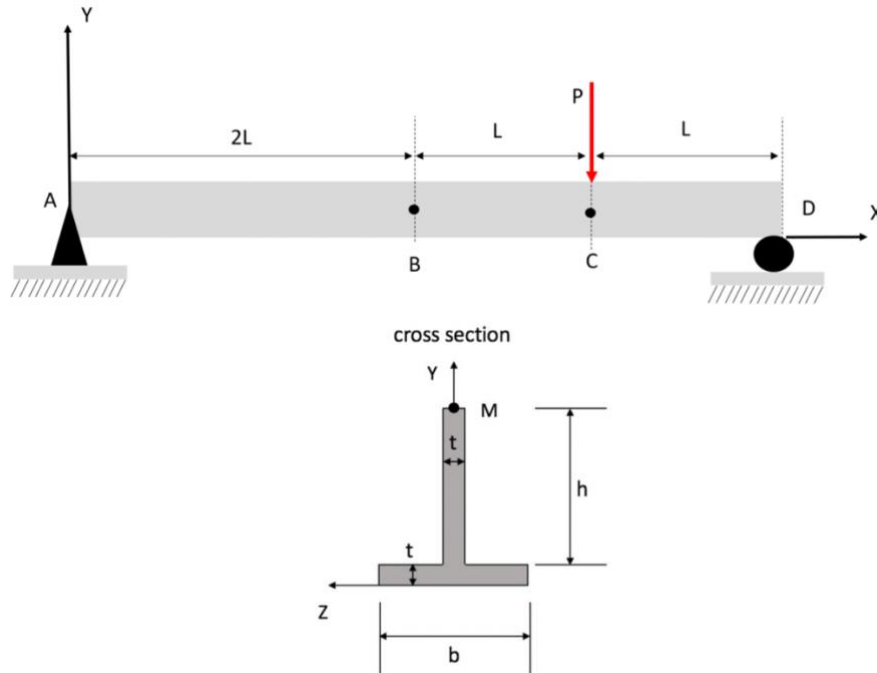

Problem 5.3 (10 points)

A design decision is to be taken based on whether a beam can support higher normal stresses in a box configuration or an H-configuration (see the two figures below), considering plane of bending is the XY plane. Assuming that both cross sections are symmetric about the origins placed at the respective centroids:

- Determine the second area moment of inertia of the two cross sections, I_{ZZ}^{BOX} and I_{ZZ}^H
- Determine which cross section would experience a lower magnitude of maximum normal stress for the same loading conditions.

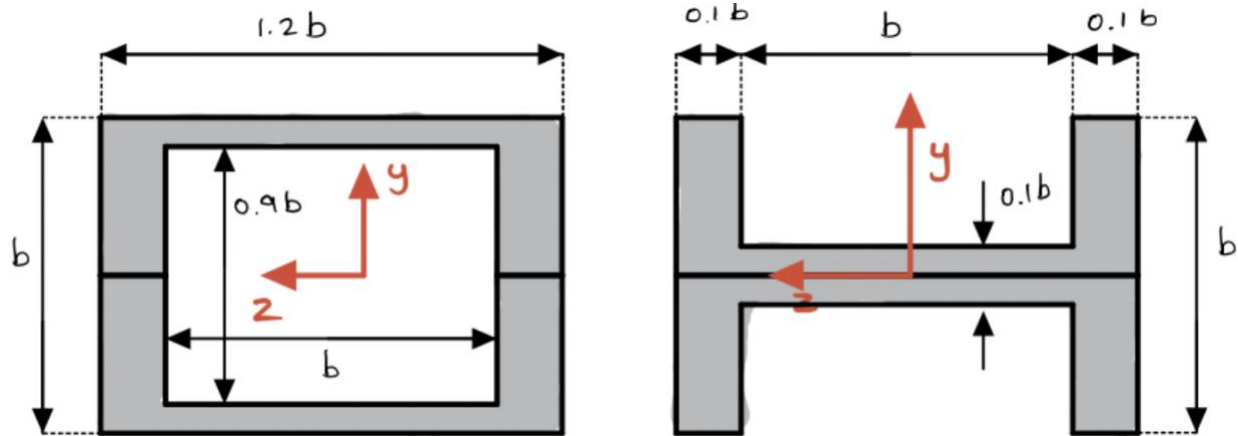

Problem 5.4 (2.5 + 2.5 points)

Part 1

A shear force V and bending moment M act at a cross section of a trapezoidal cross-sectioned beam. Consider the five points (i), (ii), (iii), (iv) and (v) on the beam cross section, as shown above. Match up the state of stress at each of these five points with the stress elements (a) through (o) shown below. If you choose “(o) NONE of the above”, provide a sketch of the correct state of stress for your answer.

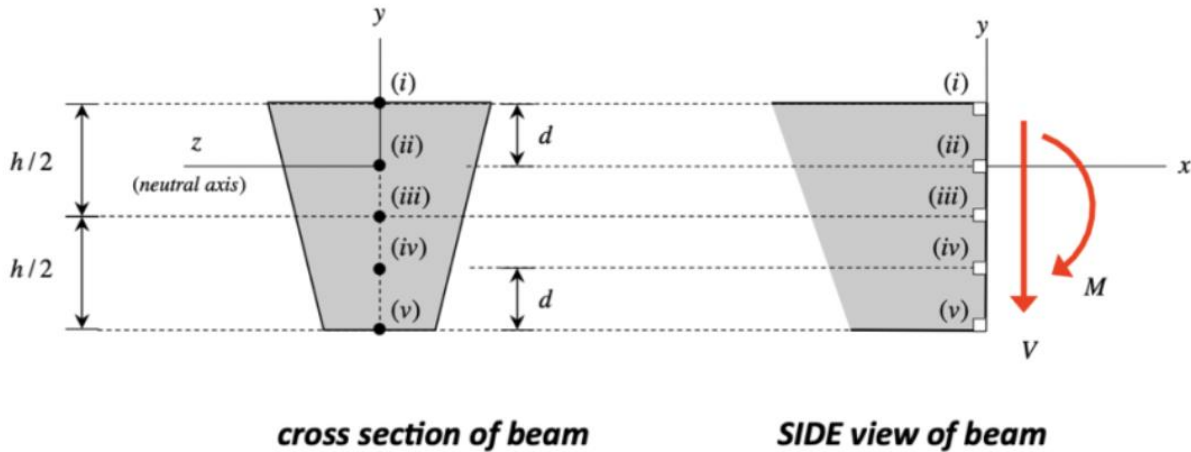

The state of stress at point (i) is

The state of stress at point (ii) is

The state of stress at point (iii) is

The state of stress at point (iv) is

The state of stress at point (v) is

(a)	(b)	(c)	(d)	(e)
(f)	(g)	(h)	(i)	(j)
(k)	(l)	(m)	(n)	(o) NONE of the above

Part 2

A beam has the T-shaped cross section shown below. The internal bending moment in the beam is known to be M .

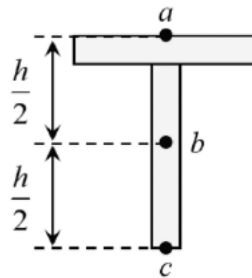

Let $|\sigma_a|$, $|\sigma_b|$, $|\sigma_c|$ be the magnitudes of the normal stress at points a, b, and c, respectively. It is desired to determine $|\sigma_{max}|$, the maximum magnitude of the normal stress on the cross section.

Choose the correct statement:

- (a) $|\sigma_{max}| = |\sigma_a|$
- (b) $|\sigma_{max}| = |\sigma_b|$
- (c) $|\sigma_{max}| = |\sigma_c|$
- (d) $|\sigma_{max}| = |\sigma_a| = |\sigma_c|$
- (e) $|\sigma_{max}| = |\sigma_a| = |\sigma_b| = |\sigma_c|$