

3. Shear Stress and Shear Strain

Objectives:

To study the relationship between stress and strain due to pure shear.

Lecture topics:

- a) Shear stress
- b) Direct shear and single/double shear in pins
- c) Shear strain
- d) Shear modulus
- e) Normal and shear components of stress in an axially-loaded member

Lecture Notes

a) Shear stress

A shear force is applied to the end of a short, stubby member, where A is the cross-sectional area of the member. A mathematical cut is made in the member that exposes a shear load distribution on face of the cut.

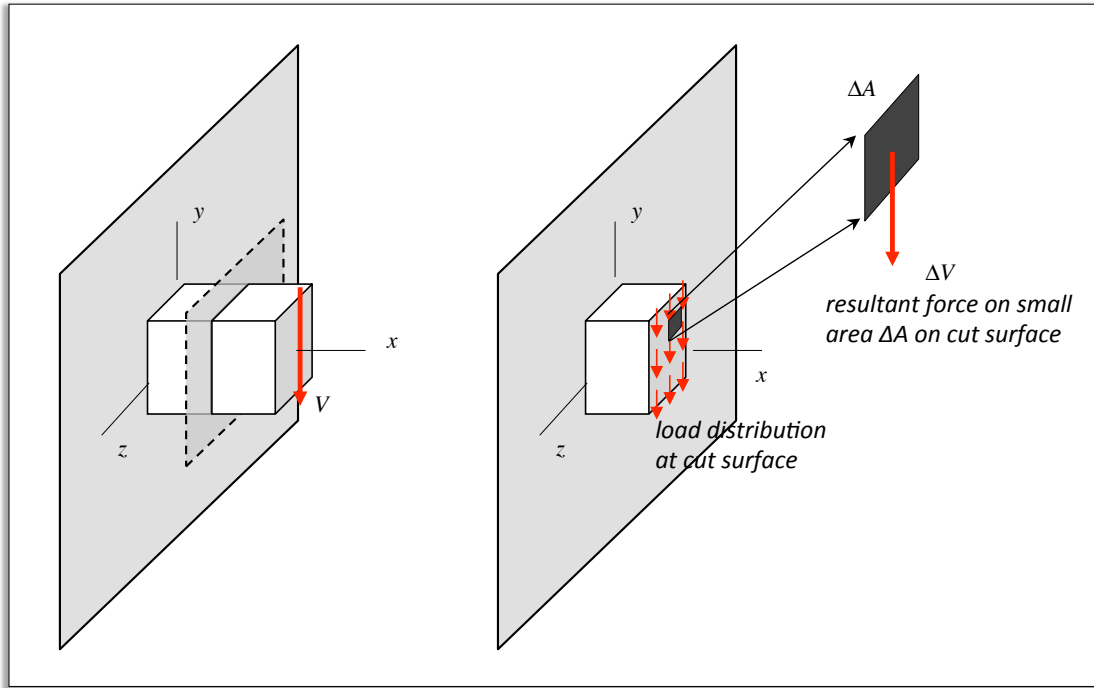

Let ΔV represent the resultant force acting over an area of ΔA on the surface. From this, we define:

$$\tau = \text{shear stress} = \lim_{\Delta A \rightarrow 0} \left(\frac{\Delta V}{\Delta A} \right) = \frac{dV}{dA} \quad \Rightarrow \quad dV = \tau dA$$

Average shear stress

From above, we have:

$$V = \int_{\text{area}} dV = \int_{\text{area}} \tau dA = \text{resultant shear force at the surface}$$

Using the definition of the average value of a function over an area:

$$\tau_{\text{ave}} = \frac{1}{A} \int_{\text{area}} \tau dA$$

we see that:

$$\tau_{\text{ave}} = \frac{V}{A}$$

b) Direct shear and single/double shear in pins

A state of direct (or simple) shear exists in a member when shear forces exist at a location in the member with an absence of normal forces or bending moments. For a state of direct shear, normal stresses do not exist, and we need to consider only shear stresses.

As an example, consider two pairs of parallel forces F acting a short distance d apart on a beam. A free body diagram analysis will show that between a pair of the two applied forces, the shear force and bending moment are given by $V = F$ and $M < Fd$, respectively. Therefore, as $d \rightarrow 0$, we see that $M \rightarrow 0$. As a result, a state of direct shear exists in the beam between the application points of this pair of forces.

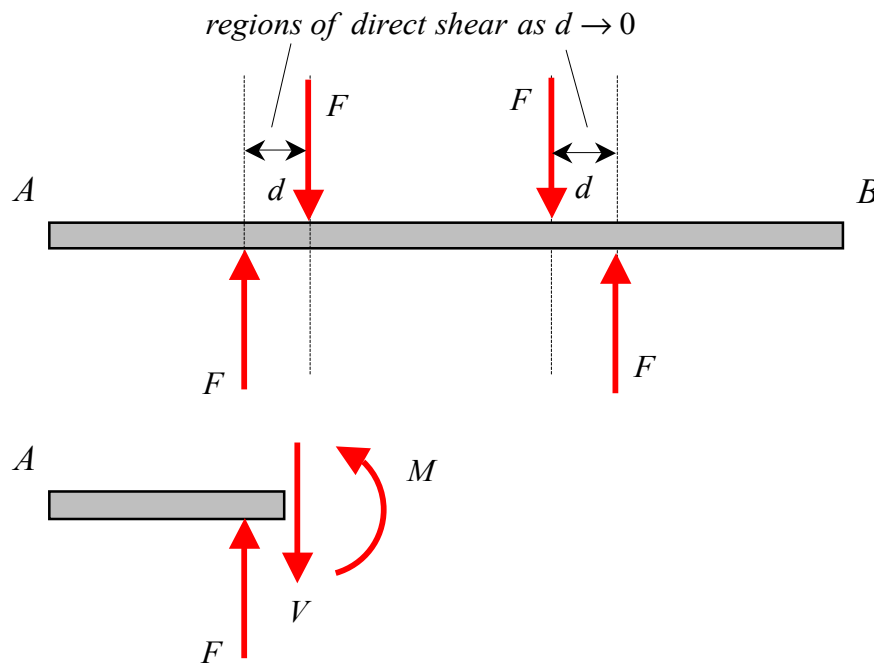

Examples of direct shear

Punching operation:

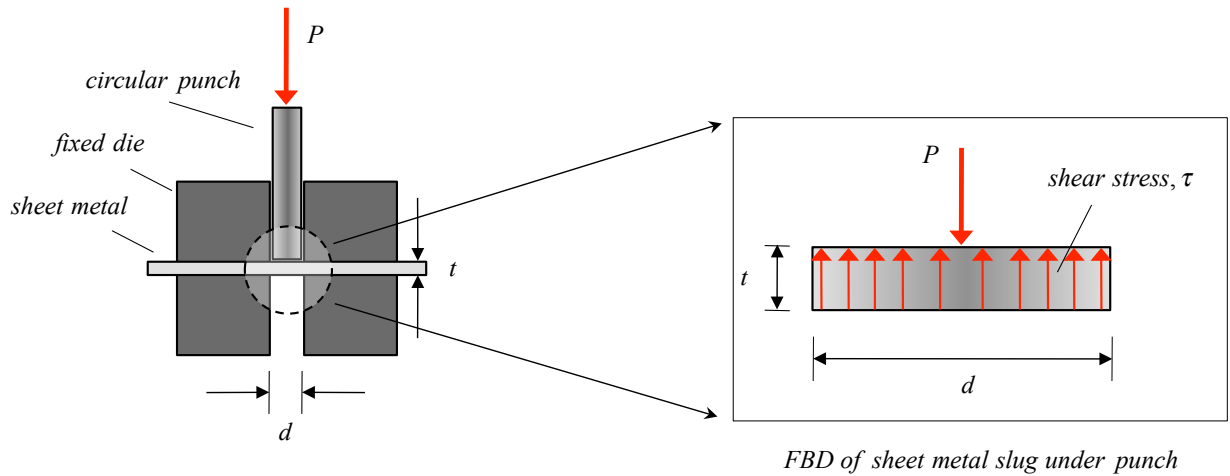

With a small clearance between the punch and the inner diameter, the sheet metal experiences a state of direct shear. Here, we can calculate the shear stress acting on the circumference of the punch slug as:

$$\tau = \frac{V}{A} = \frac{P}{\pi dt}$$

Bolted and pinned connections:

Single-shear

Consider a rod connected to a hinge with pin having a diameter of d . The hinge has a *single* support to ground. The rod carries an axial load of P . What is the average shear stress in the pin?

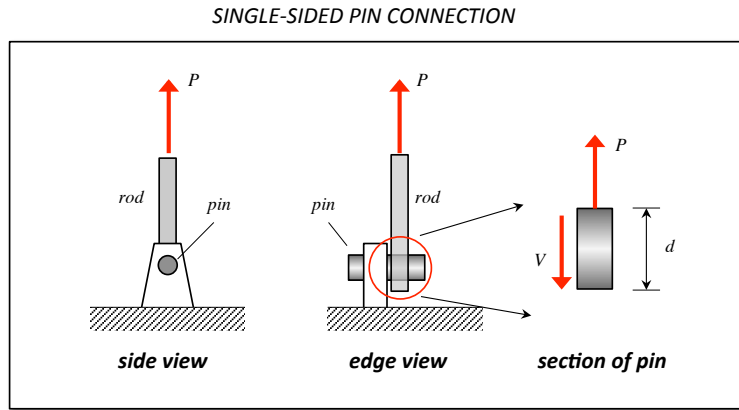

$$\sum F = P - V = 0 \Rightarrow P = V$$

Therefore the average shear stress in the pin is:

$$\tau = \frac{V}{A} = \frac{P}{\pi(d/2)^2} = \frac{4P}{\pi d^2}$$

Double-shear

Consider a rod connected to a hinge with pin having a diameter of d . The hinge has a *double* support to ground. The rod carries an axial load of P . What is the average shear stress in the pin?

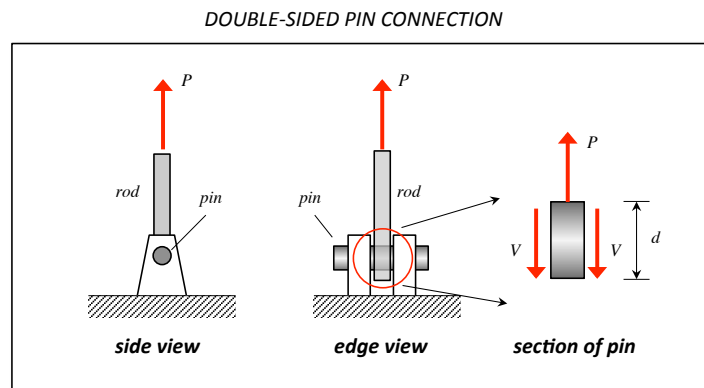

$$\sum F = P - 2V = 0 \Rightarrow V = P/2$$

Therefore the average shear stress in the pin is:

$$\tau = \frac{V}{A} = \frac{P/2}{\pi(d/2)^2} = \frac{2P}{\pi d^2}$$

c) Shear strain

Consider the loading of the element below by a shear force V :

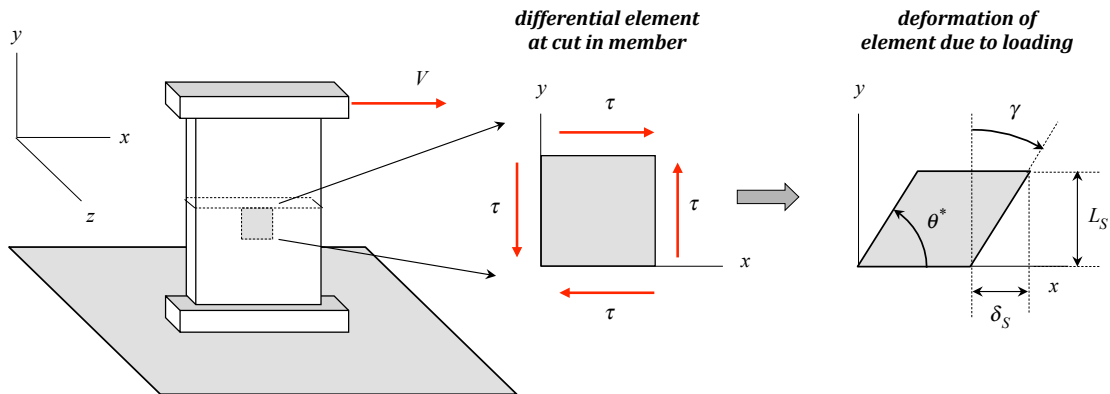

Shear strain deformations produce skewing in a rectangular-shaped element: the angle between adjacent sides changes from $\pi / 2$ to θ^* . Here, we will define the shear strain as γ representing this change in angle:

$$\gamma = \text{shear strain} = \frac{\pi}{2} - \theta^*$$

where, from the figure, we have:

$$\tan \gamma = \frac{\delta_s}{L_s}$$

For small strains, $\tan \gamma \approx \gamma$, and therefore,

$$\gamma = \frac{\pi}{2} - \theta^* \approx \frac{\delta_s}{L_s}$$

d) Material properties in shear – shear modulus

The relationship between shear stress and shear strain, as with those between normal stress and axial strains, is determined from experimental tests. Experiments show that for linear behavior of materials, the stress/strain relationship is given by:

$$\tau = G\gamma$$

where G is the “shear modulus” for the material. Note that the shear modulus has units of force per unit area (e.g., $lb / in^2 = psi$ and $N / m^2 = Pa$).

The shear properties of a linearly elastic material are closely related to the extensional properties through equations of equilibrium and geometry of deformation. In particular, the following relationship can be derived:

$$G = \frac{E}{2(1 + \nu)}$$

where E is the Young’s modulus and ν is the Poisson’s ratio for the material.

e) Normal and shear components of stress in an axially-loaded member

As a closing note, let's consider the stresses in an axially-loaded rod with a cross-sectional area of A . Here we will make a cut through the rod that is perpendicular to the rod axis, as shown below.

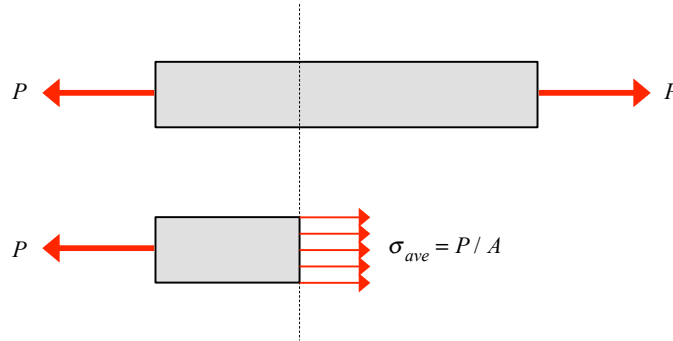

Since the axial load throughout the rod is P , we can write down that the average axial stress is the axial force divided by the cross-sectional area:

$$\sigma_{ave} = \frac{P}{A}$$

Also, since the axial load is perpendicular to cut face, the shear stress on the cut face is zero.

Suppose, instead, we make a cut through the rod at an angle θ , as shown in the following figure.

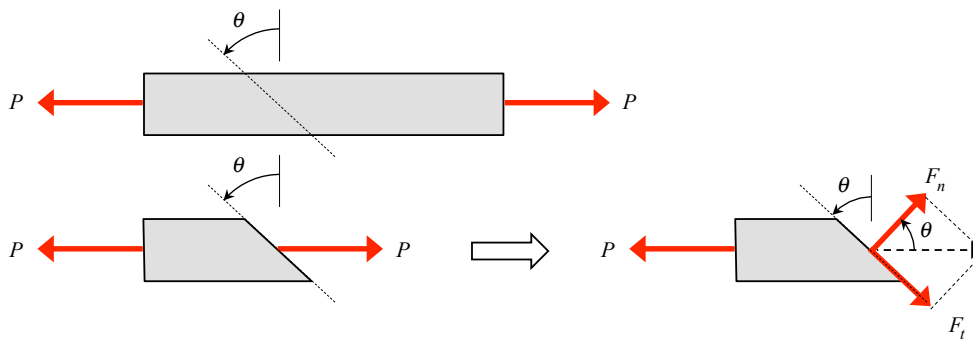

As a result of this cut, we see two changes. First, the axial load now has both normal and tangential components on the cut face of:

$$F_n = P \cos \theta$$

$$F_t = P \sin \theta$$

respectively. Second, the area of the cross section over which these resultant components act is larger:

$$A_c = \frac{A}{\cos \theta}$$

With this, the components of stress normal and tangent to the cut are now written as:

$$\sigma = \frac{F_n}{A_c} = \frac{P \cos \theta}{A / \cos \theta} = \frac{P}{A} \cos^2 \theta = \frac{P}{2A} (1 + \cos 2\theta)$$

$$\tau = \frac{F_t}{A_c} = \frac{P \sin \theta}{A / \cos \theta} = \frac{P}{A} \cos \theta \sin \theta = \frac{P}{2A} \sin 2\theta$$

From this, we see that the orientation of the cut through the member influences the values of normal and shear components of stress. Furthermore, we see that an axial loading can produce both normal and shear components of stress. (Note that the maximum shear stress occurs for a cut at $\theta = 45^\circ$, where $\tau = P / 2A$.)

Example 3.1

A hydraulic punch press that can apply a maximum punch force of P_{\max} is used to punch circular holes in an aluminum plate of thickness t . If the average punching shear resistance of this plate is τ , what is the maximum diameter d of the hole that can be punched?

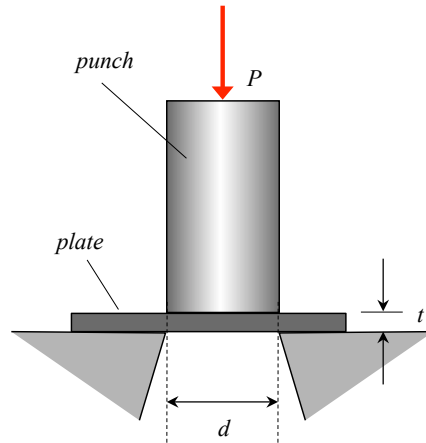

Example 3.2

Two boards are spliced together using four bolts (each of diameter d) running through the boards and two steel splice plates, as shown below. The average direct shear stress experienced by each bolt is known to be τ . What is the value of the tensile load P carried by the spliced boards?

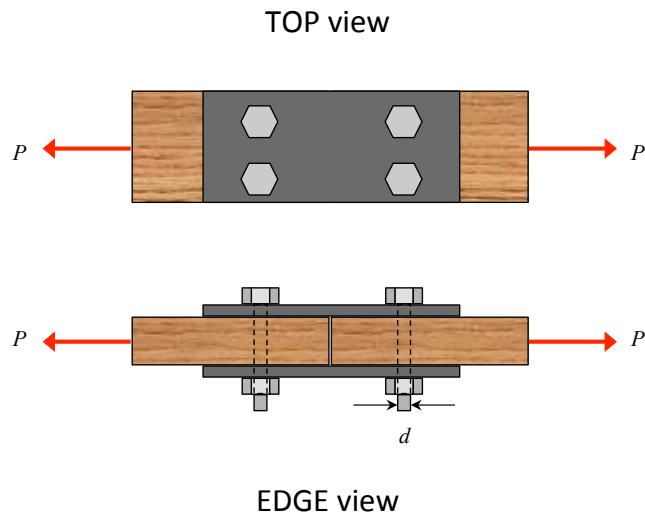

Example 3.3

The pin at C has a diameter of D . Determine the average shear stress in the pin at C. Neglect the weight of link AC.

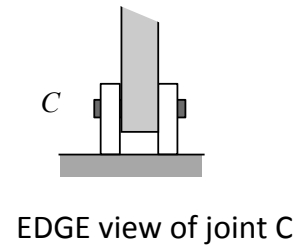
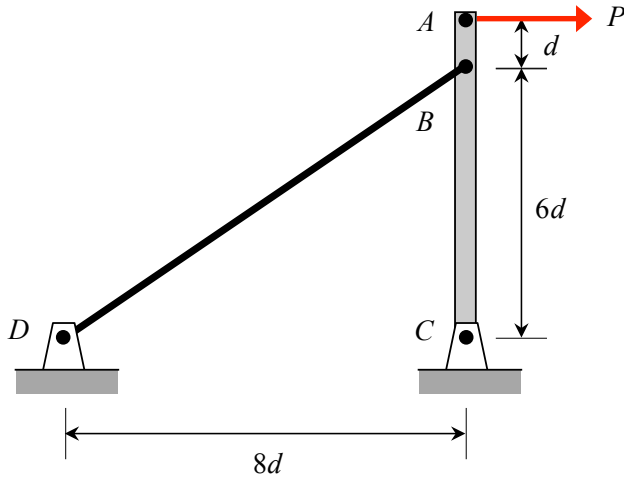

Example 3.5

A spherical tank (having an inner radius of R) is half-filled with a liquid that has a mass density of ρ . The tank is supported by a pin joint at B and by a cable at C (at the top of the tank). The pin joint at B is a double-sided connection, whereas the cable is attached to the tank at C with a single-sided connection. The pins at B and C are identical, each having a diameter of D . Determine the shear stress in pins B and C . Assume that the weight of the tank is negligible compared to the weight of the liquid that it contains.

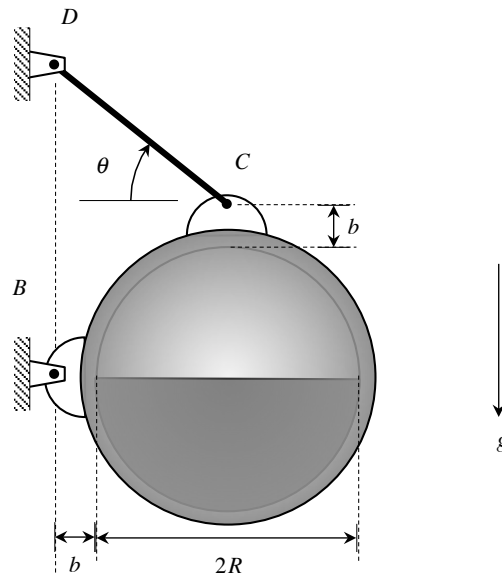

Example 3.6

A prismatic bar has an equilateral triangle cross section, with the sides of the equilateral triangle being b . Determine the normal and shear components of stress on a cross section of the bar with the cross section oriented at an angle of θ from the y axis, as shown in the figure below. At what angle θ is the shear stress a maximum, and what is the value of the maximum shear stress?

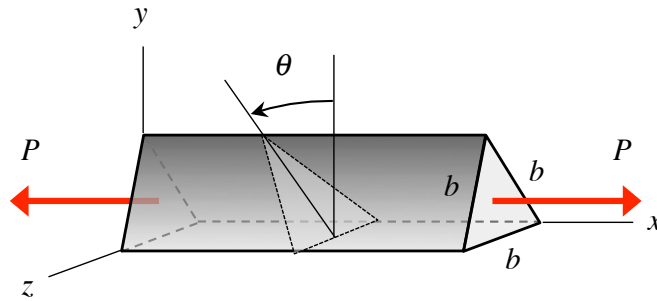

Additional notes:

