



INSTRUCTION MANUAL

MODEL: C-916S

SERIAL NO: 529-96101 to

BAND SAWING MACHINE

DAMAGE CLAIM PROCEDURES

VISIBLE DAMAGE AT THE TIME OF DELIVERY:

1. Note damage on carrier's delivery receipt. Accept the shipment. It can be returned later if repairs are not possible in the field.
2. Request a "damage inspection" from the delivery carrier:
 - a. The carrier will send his own people or contract an independent agency to make the inspection.
 - b. The inspector will request a signature on the report and leave a copy.
 - c. The carrier "damage inspection" report is not final. If additional damage is found when repairs are started, contact the carrier for another inspection; or at least give them the details of the damage.
3. Do not move the equipment from the receiving area and keep all shipping materials until carrier "damage inspection" report is complete.
4. If possible, take photographs of the damage and keep them for your files. Photos could possibly prove a claim at a later time.
5. Keep a record of all expenses and be sure they are documented.
6. Repair damage in the field whenever possible. Carriers encourage this to keep expenses down.
7. You have nine (9) months to file a claim.

CONCEALED DAMAGE:

1. You have fourteen (14) days to report damage not noted at time of delivery.
 - a. Report damage as soon as possible. This makes it easier to prove that it did not happen at cosignee's plant.
 - b. Inspect machine(s) carefully before moving from the receiving area. Again, if machine is not moved, it is easier to prove your case.
2. Request a "damage inspection" from the delivery carrier:
 - a. The carrier will send his own people or contract an independent agency to make the inspection.
 - b. The inspector will request a signature on the report and leave a copy.
 - c. The carrier "damage inspection" report is not final. If additional damage is found when repairs are started, contact the carrier for another inspection; or at least give them the details of the damage.
3. Do not move the equipment from the receiving area and keep all shipping materials until carrier "damage inspection" report is complete.
4. If possible, take photographs of the damage and keep them for your files. Photos could possibly prove a claim at a later time.
5. Keep a record of all expenses and be sure they are documented.
6. Repair damage in the field whenever possible. Carriers encourage this to keep expenses down.
7. You have nine (9) months to file a claim.

OPERATOR'S INSTRUCTION MANUAL

METAL CUTTING BAND SAW







MODEL

FIRST SERIAL NO.

LAST SERIAL NO.

C-916S

529-96101

MACHINE MODEL				SERIAL NUMBER	
<input type="text"/>				<input type="text"/>	
TOTAL MACHINE ELECTRICAL POWER INPUT DATA					
VOLTAGE	PHASE	HERTZ	FULL LOAD AMPS		
<input type="text"/>	<input type="text"/>	<input type="text"/>	<input type="text"/>		
V			A		
LARGEST CONTROLLED MOTOR		 OVERCURRENT PROTECTION PROVIDED AT MACHINE SUPPLY TERMINAL			
<input type="text"/>					
FIELD ALIGN & ADJUST SUMMARY			BAND LENGTH 		
<input type="text"/>			<input type="text"/>		
ELECTRICAL SCHEMATIC NUMBER			DATE OF MANUFACTURE		
<input type="text"/>			<input type="text"/>		
HYDRAULIC SCHEMATIC NUMBER			 SEE INSTRUCTION MANUAL FOR MACHINE OPERATION AND LUBRICATION DATA		
<input type="text"/>					

For your information and future reference, pertinent data concerning your machine should be written in the spaces provided above. This information is stamped on a plate attached to your machine. Be sure to provide machine model and serial numbers with any correspondence or parts orders.

Specifications contained herein were in effect at the time this manual was approved for printing. The DoALL Company, whose policy is one of continuous improvement, reserves the right, however, to change specifications or design at any time without notice and without incurring obligations.

PLEASE READ THIS MANUAL CAREFULLY BEFORE OPERATING THE MACHINE!



DoALL SAWING PRODUCTS
 2375B TOUHY AVENUE
 ELK GROVE, ILLINOIS 60007 U.S.A.

The following registered trademarks of the DoALL Company are used in this manual: DoALL, Dart, Imperial Bi-Metal, Kleen-Kool, and Tensigage.

TABLE OF CONTENTS

MACHINE DIMENSIONS

Floor Plan and Top View	1
Front and Side Views	2

MACHINE FEATURES

Front and Side Views	3
----------------------------	---

INSTALLATION

Location	4
OSHA Notice	4
Unpacking	4
Cleaning	4
Lifting	4
Floor Installation and Alignment	4-5
Electrical Installation	5
Plant Air Installation (If Supplied)	5
Preparation for Use	6

OPERATION

Safety Precautions	7
Using the Job Selector	7
Cutting Capacity	7
Control Panel	7-8
Saw Band Preparation	9-10
Band Speed Adjustment	10
Head Feed Adjustment	10
Vise Jaw Adjustment	11
Coolant Selection and Application	11-12
Dry Cutting	12
Band Brush and Chip Removal	12
Typical Operation Procedures	13

LUBRICATION

Lubrication Chart	14
Lubrication Diagram	15

MAINTENANCE

Saw Guide Insert Replacement	16
Drive Belt Removal or Replacement	16
Band Tension Adjustment	16
Coolant System	16-17
Chip Removal	17
Replacing Vise Bed Wear Plates	17
Bandwheels	17
Head Feed Cylinder	17-18
Counterbalance Spring	18

TROUBLE SHOOTING

19-21

ACCESSORIES

Roller Stock Conveyors	22
Vertical Guide Rollers	22
Pneumatic Head Lift	22-23
Band Lubricator	23
Pneumatic Vise	23
Full Cycle Option	23-24
Optional Band Speed	24
Flushing Hose	24
Workstop	24
Idler Wheel Motion Detector	25
Worklight	25

How to read your serial number:

Example: 500-001234

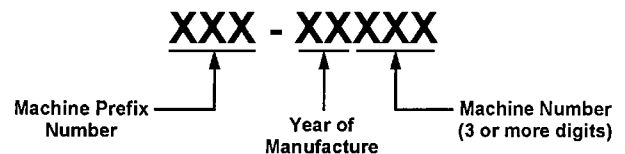

MACHINE DIMENSIONS

INCHES ($\pm .03$)
MILLIMETERS (± 1 mm)

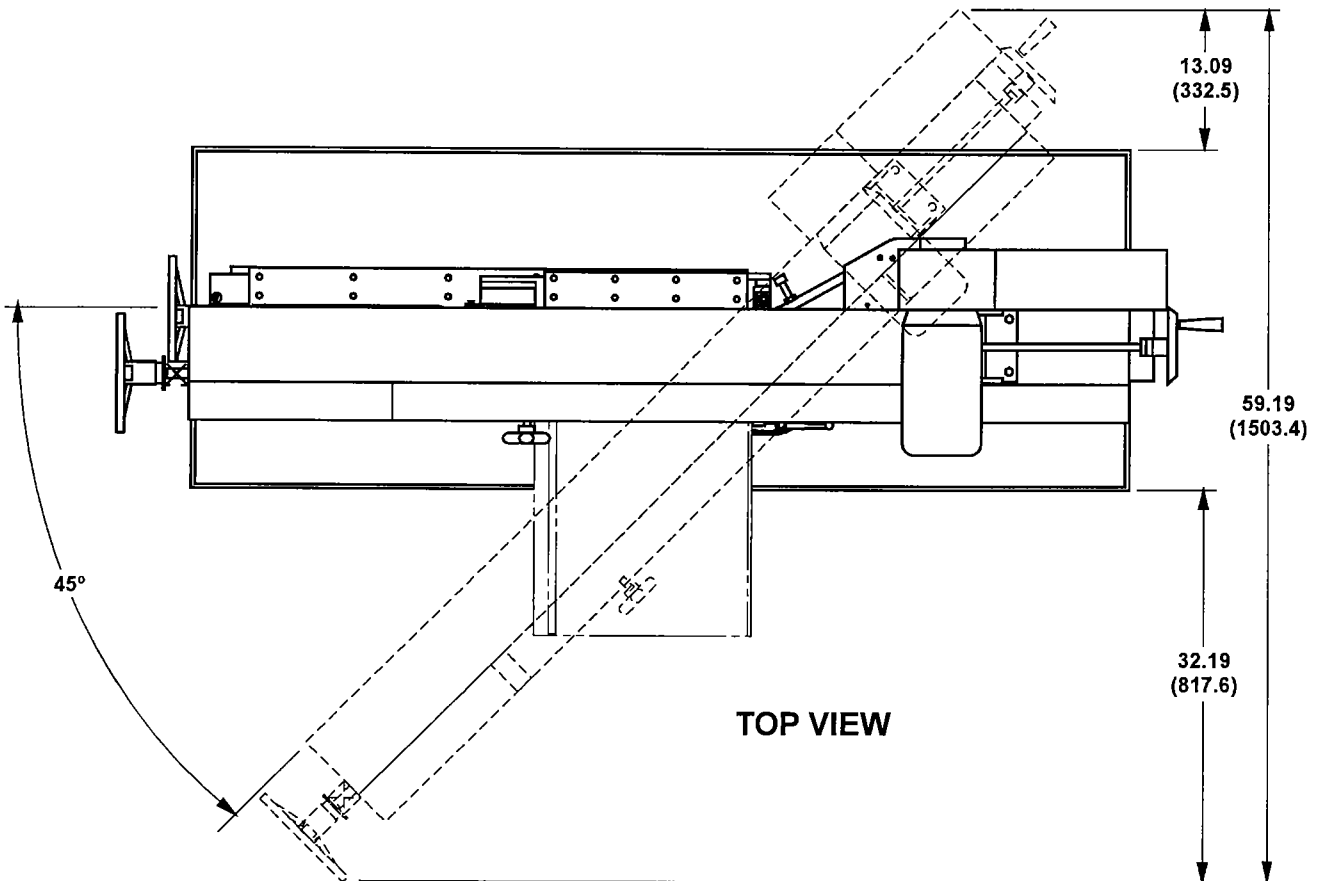
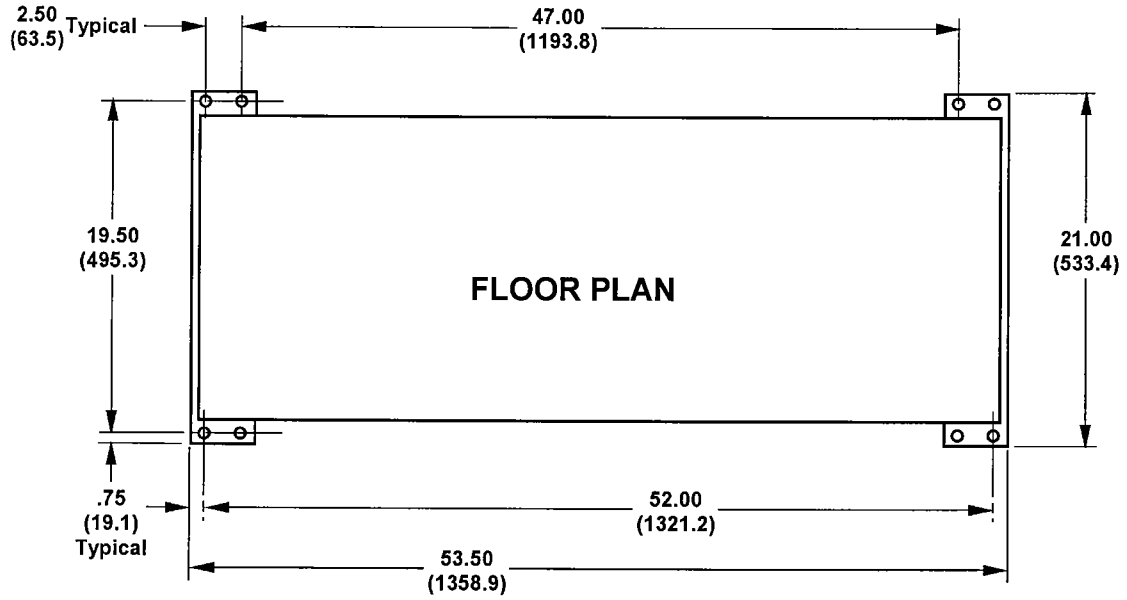

MACHINE DIMENSIONS (Continued...)

INCHES ($\pm .03$)
MILLIMETERS (± 1 mm)

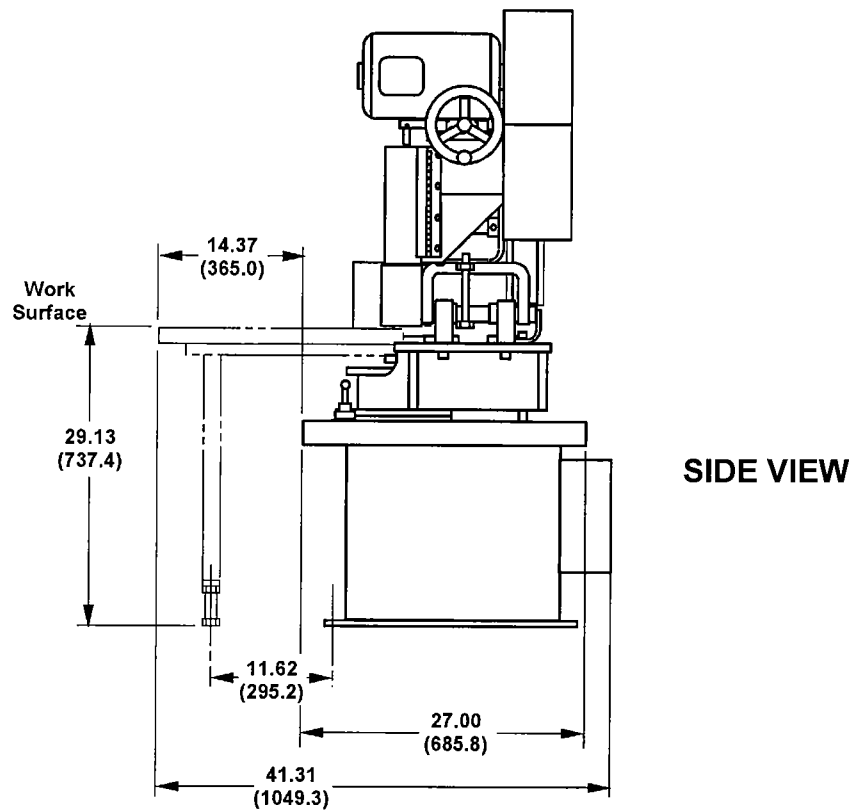
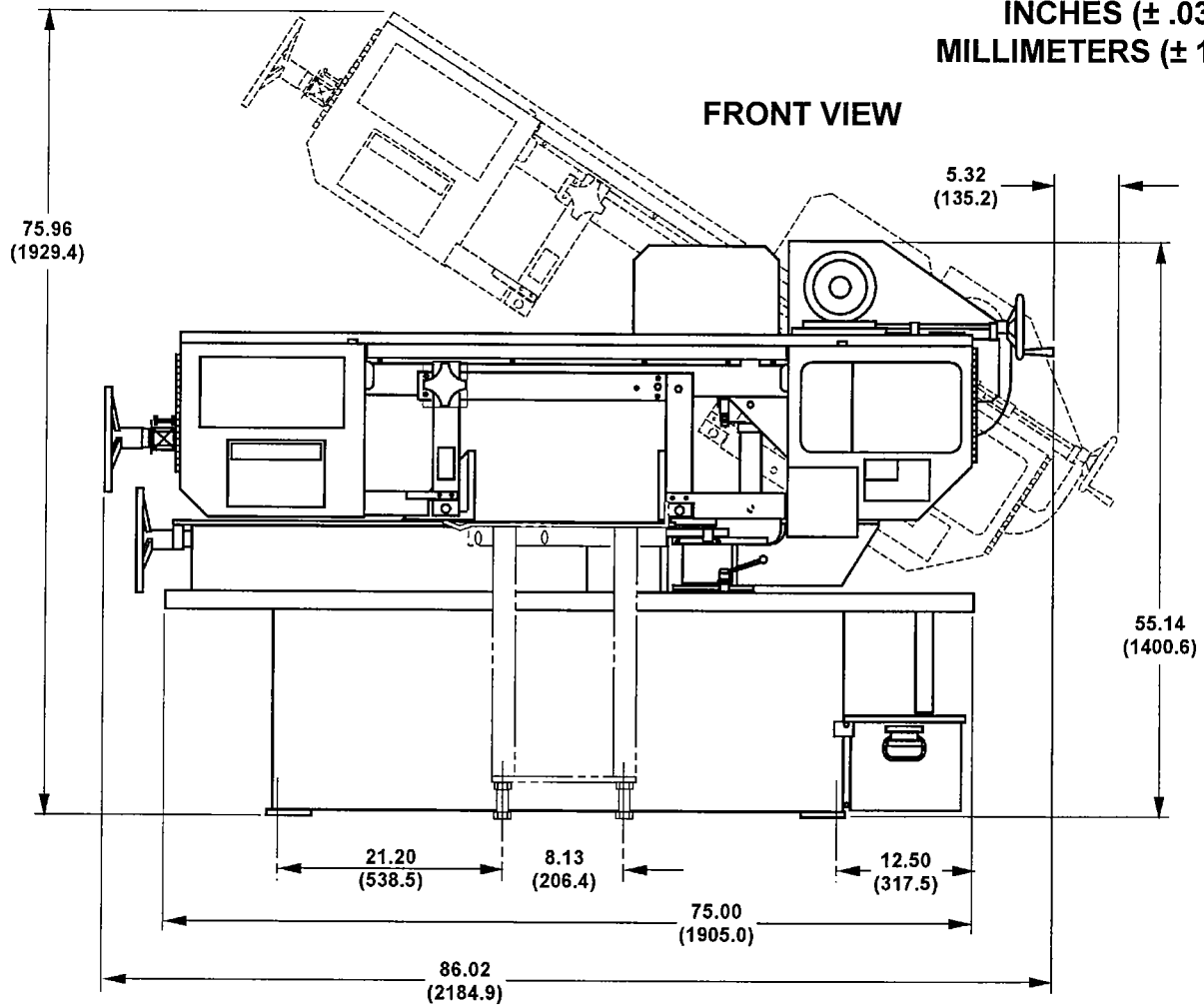

MACHINE FEATURES

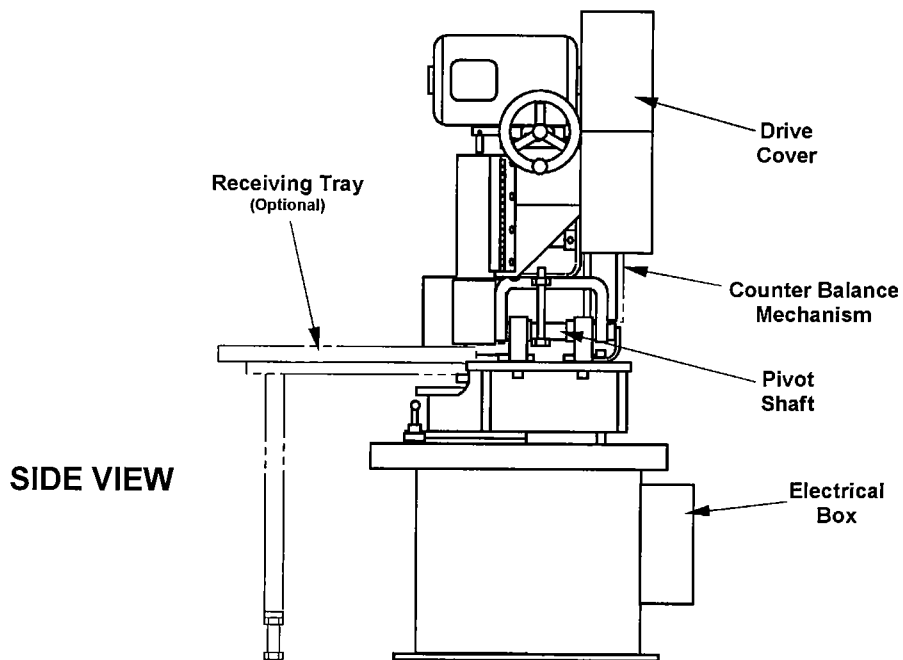
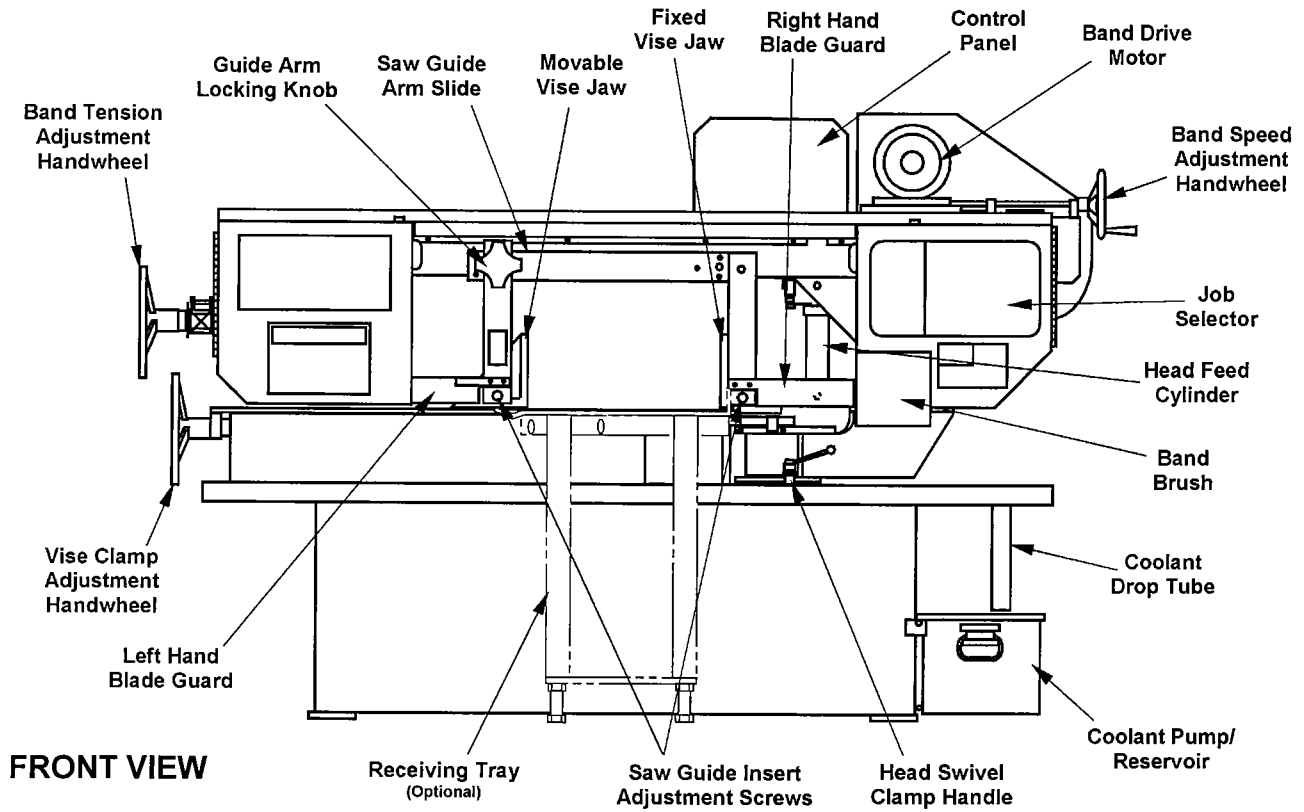

INSTALLATION



All "left", "right", "front", "rear" directions in this manual are as viewed by the operator when facing the control panel.

LOCATION

1. Position the machine to allow adequate space for stock feeding and removal with maximum convenience.
2. Allow sufficient space for saw head elevation, bandwheel door opening, plus lubrication and maintenance procedures.
3. Approximate floor dimensions for the machine are shown on pages 1 and 2.
4. Accessories such as roller stock conveyors will require additional working area.

OSHA NOTICE!



OSHA Regulation No. 1910.212 (5B).
Machines designed for a fixed location shall be securely anchored to prevent walking or moving.

UNPACKING

1. The machine and discharge tray, plus other parts and supplies were fastened to a wooden skid before shipment.
2. Remove all protective covers, strapping, crating, etc. Then: **(a)** Remove wire if used to secure bandwheel doors and/or bandwheels; **(b)** Remove the bolts or screws attaching the machine to the shipping skid.



DO NOT remove the metal bracket holding the saw head to the base until the machine has been lifted to its permanent location.

3. Inspect the machine for broken or damaged parts. Refer to this manual's inside front cover for damage claim procedures.

CLEANING

1. Use solvent to remove the rust-preventative coating applied to the machine's exposed bare metal surfaces before shipping if required.

LIFTING



Never lift the machine by its sawing head.

1. Use a fork lift truck or overhead hoist to lift the machine to its permanent location. Net weight is approximately 1150 pounds (521.6 kg).
2. If using a fork lift, spread the forks to provide even machine weight distribution and to protect against frame stress. If a hoist is used, be sure to position padding where the sling makes contact with the machine frame.
3. Accessory roller stock conveyors can be lifted into position using a fork lift or other means that provides adequate safety precautions.

Relocation Procedures

1. Should machine relocation become necessary at a later date, it will be extremely important to protect the frame against undue stress. Before moving, reinstall the shipping bracket connecting the saw head to the base.
2. To move the machine with a fork lift truck, proceed as follows: **(a)** Place a 2 x 4 wooden plank below and between the base pads on the machine's two (2) front pad weldments; **(b)** Place another 2 x 4 wooden plank below and between the base pads on the machine's two (2) rear pad weldments; **(c)** If the fork lift is adjustable for width, place the forks directly below the 2 x 4s and as close as possible to the positions shown in the illustration.

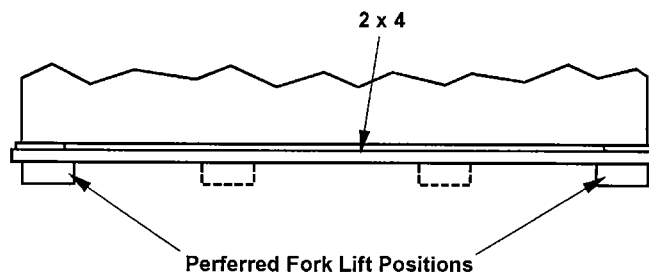

Carefully Position the Lift Forks.

FLOOR INSTALLATION AND ALIGNMENT

1. Remove the machine from its shipping skid and place it in the desired location. Remove the bracket holding the saw head to the base. **Save this bracket for use in case machine relocation becomes necessary at a future date.**

FLOOR INSTALLATION AND ALIGNMENT (Continued...)

- Place a machinist's level on the vise bed. If the machine is not level, correct it by: **(a)** Adjusting the four (4) leveling screws on the base; **(b)** Tighten the jam nuts. **Machine must rest evenly on all pads.**

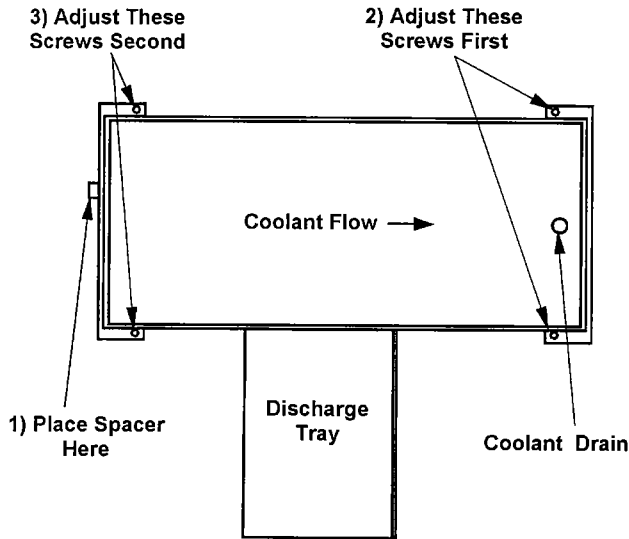

Leveling the Machine.

- Place a 3/4-inch (19.0 mm) spacer (approximately one (1) inch square (25.4 mm) under the base pad midway on the left side edge of the base. Then: **(a)** Adjust the leveling screws on the left side until they contact the floor; **(b)** Give both screws another 1/2 turn.
- Place coolant in the base pan and check its flow to the right side drain hole. If the coolant does not flow as desired: **(a)** Add a thicker spacer at the midpoint of the base pad; **(b)** Repeat step 3 above until coolant drainage is achieved.
- Install anchoring screws through the base pad holes next to the leveling screw locations.

Band Speed Handwheel (Older Machines)

- The handle was installed on the handwheel on the inside to prevent damage during shipment. Remove the handle and related hardware.

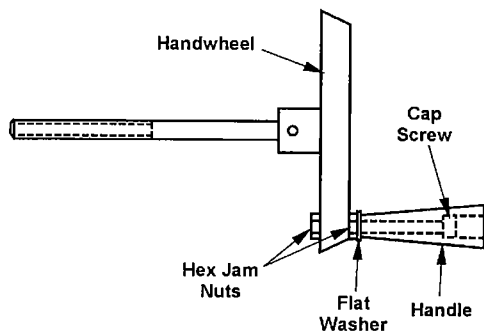

Band Speed Adjustment Handwheel.

- To install the handle to the handwheel: **(a)** Place the cap screw through the handle and into the flat washer; **(b)** Thread a hex jam nut up against the flat washer; **(c)** Adjust the jam nut away from the washer just enough to allow the handle to turn freely; **(d)** Install this assembly into the handwheel shown in the illustration; **(e)** Use a 5/16-inch (7.9 mm) Allen wrench to hold the cap screw in place and thread the other hex jam nut onto the end of the cap screw and tighten; **(f)** Repeat steps **(c)** through **(e)** until the necessary handle tightness is obtained.

Receiving Tray Installation

- Assemble the leg weldments to the tray weldment with four (4) M8 screws and washers. Then: **(a)** Insert M12 screws and jam nuts into the leg weldment to serve as leveling screws; **(b)** Position the assembled tray at the machine front and attach to the frame bracket with three (3) M8 screws and washers; **(c)** Adjust the tray's leveling screws so its surface is flush with the machine's vise base, or no more than 0.031 inch (0.8 mm) below it; **(d)** Elevate the tray's right side slightly so used coolant will drain into the machine's base pan.

ELECTRICAL INSTALLATION



Electrical installation must be made by authorized electrical maintenance personnel!

- Bring the incoming line circuit leads to the disconnect switch terminals in the electrical control box located on the lower left side in the rear of the machine base. Refer to the furnished electrical schematic, if necessary.
- When the machine is correctly wired, the saw band will run left to right through the saw guides when viewed from the front. Reverse the incoming line leads if movement is not correct.

PLANT AIR INSTALLATION (If Supplied)

- Plant air is required to operate the following optional equipment: vise clamp cylinder, head lift cylinder and mist lube system.
- Plant air is connected at the air filter on the lower base in the rear of the machine. Air pressure should be in the range of 80 to 90 psi (5.4 - 6.1 bar).



DO NOT exceed 90 psi (6.1 bar).

PREPARATION FOR USE

1. Make electrical connections to the machine while referring to the electrical schematic.
2. All covers and guards must be in place, doors must be closed, and operator understands the safety rules and operation of the machine.
3. Place the coolant deflector under the trough of the receiving tray in the coolant pan. The splash guard latches onto the lip of the coolant pan in front of the right bandwheel door.

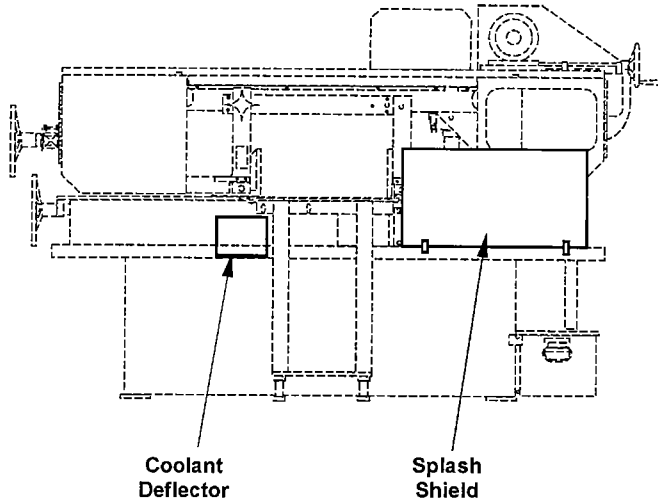

Placement of Coolant Deflector and Shield.

4. Fill coolant reservoir with coolant recommended in the Lubrication Chart. Be sure that all other points listed in the Lubrication Chart have been checked and/or serviced.

Break-In Cut

1. The initial cut with a new machine should be made with a band speed at 105 fpm (32 m/min.) and a light feed force. **This is extremely important because the saw band will be cutting partially into the receiving tray (thus establishing a future kerf path).**
2. During the break-in cut, allow blade penetration into the receiving tray until the saw head reaches the factory-set mechanical stop (horizontal position).



Be sure the saw head falls only enough to cut completely through the work. TOO MUCH head fall could result in cutting the receiving tray too deeply or completely off. TOO LITTLE head fall will result in an incomplete cut through the workpiece. See the Engineering Adjustment Summary supplied with your machine for instructions on adjusting the counterbalance spring mechanism.

OPERATION

SAFETY PRECAUTIONS

SUPERVISOR, MAKE SURE THAT THE OPERATOR UNDERSTANDS THE FOLLOWING:

WARNING

THESE PRECAUTIONS MUST BE FOLLOWED WHEN OPERATING OR SERVICING THIS MACHINE:

- NEVER WEAR GLOVES WHILE OPERATING THIS MACHINE.
- NEVER OPERATE MACHINE WITHOUT SAFETY GLASSES.
- NEVER OPERATE MACHINE WITHOUT SAW BLADE GUARDS IN PLACE.
- NEVER OPERATE MACHINE BEFORE CLOSING BAND WHEEL DOOR COVERS.
- NEVER OPERATE MACHINE FROM REAR.
- NEVER REMOVE CUT-OFF PIECES WHILE MACHINE IS RUNNING.
- READ INSTRUCTION MANUALS BEFORE OPERATING THIS MACHINE.
- AVOID CONTACT WITH COOLANT, ESPECIALLY GUARD YOUR EYES.
- BRING ADJUSTABLE SAW GUIDE AND GUARD AS CLOSE TO WORK AS POSSIBLE.
- DISCONNECT ALL ELECTRICAL POWER BEFORE SERVICING.
- DO NOT SERVICE, REPAIR OR ADJUST MACHINE WITHOUT PROPER INSTRUCTION FROM YOUR SUPERVISOR AND WITHOUT READING AND FULLY UNDERSTANDING THE INSTRUCTION MANUAL.
- USE A FIXTURE TO FEED MATERIAL.
- CLOSE AND SECURE BAND WHEEL COVERS BEFORE TENSIONING BAND OR STARTING MACHINE.
- STEP TO ONE SIDE AND AWAY FROM WELDING UNIT BEFORE WELDING A SAW BAND.
- KEEP HANDS AWAY FROM MOVING SAW BLADES AND VISE AREA.
- INSTALL FRICTION BAND AND SPARK SHIELD BEFORE FRICTION SAWING.
- USE EXTREME CARE IN HANDLING BLADES.
- USE A DUST COLLECTOR WHEN SAWING GENERATES DUST.

**MAKE SAFETY THE RULE AND FOLLOW SAFE SHOP PRACTICES.
DO NOT REMOVE OR DEFACE THIS SIGN**

404476

Warning Label - READ and UNDERSTAND.

USING THE JOB SELECTOR

1. Refer to the Job Selector escutcheon on the right front bandwheel door for information about blade choice and pitch, and suggested band speed for stock type and thickness. It also provides a handy sawing procedures checklist.
2. For example, to cut low carbon steel which is two (2) inches (50 mm) thick, you would choose: (a) An Imperial Bi-Metal saw band with 8-10 pitch, and set the band speed for 275 fpm (84 m/min); or (b) A Dart saw band with 8-10 pitch, and set the band speed for 180 fpm (55 m/min).

CUTTING CAPACITY

1. Your machine is designed to cut rectangular stock up to nine (9) inches (228.6 mm) high and 16 inches (406.4 mm) wide. It will also cut round stock up to 10-3/4 inches (273.0 mm) in diameter.
2. With the saw head adjusted for 45° cutting, the machine will saw rectangular stock up to ten (10) inches (254.0 mm) high and 9 inches (228.6 mm) wide. It will also cut round stock up to ten (10) inches (254.0 mm) in diameter.
3. Vise bed capacity is 1800 pounds (816.5 kg) evenly distributed.

CONTROL PANEL

1. **Band Start.** Push this green button to activate the band drive motor and saw band.



Be sure the saw band is properly tensioned before pushing this button.

2. **Band Stop.** Push this red button to stop the band drive motor.

DEWALT

**Job Selector
Model C-916**

CHECK LIST AND GUIDE FOR MACHINE OPERATOR

- ✓ READ AND OBSERVE SAFE OPERATOR PRACTICES.
- ✓ READ INSTRUCTION MANUAL BEFORE OPERATION.
- ✓ PROPER BAND TENSION & FLUID.
- ✓ SAW GUIDE AND CLAMPED IN PROPER POSITION.
- ✓ SAW GUIDE INVERT ADJUSTMENT IS CORRECT.
- ✓ VISE FRICTION IS CLAMPED SECURELY.
- ✓ PROPER BAND SPEED KNOWN AND SET.
- ✓ COOLANT FLOW ADJUSTMENT IS CORRECT.
- ✓ FEED FORCE ADJUSTMENT IS CORRECT.
- ✓ PROPER BAND AND TOOTH FORM SELECTED.

THE NUMBER OF PAGES OF THIS INSTRUCTION MANUAL VARY BY THE REGIONAL SALES OFFICE.

U.S.A. SYSTEM				METRIC SYSTEM			
BLADE TYPE	PITCH	THICKNESS	MATERIAL	THICKNESS	PITCH	RADIO SPEED	RECOMMENDED BAND TYPE
275	10	8-10	UP CARB. STEEL	UP TO 25	8-10	45	BI-METAL
280	10	8-10	UP CARB. STEEL	UP TO 25	8-10	45	BI-METAL
285	10	8-10	UP TO 25	8-10	45	BI-METAL	BI-METAL
290	10	8-10	UP TO 25	8-10	45	BI-METAL	BI-METAL
295	10	8-10	UP TO 25	8-10	45	BI-METAL	BI-METAL
300	10	8-10	UP TO 25	8-10	45	BI-METAL	BI-METAL
305	10	8-10	UP TO 25	8-10	45	BI-METAL	BI-METAL
310	10	8-10	UP TO 25	8-10	45	BI-METAL	BI-METAL
315	10	8-10	UP TO 25	8-10	45	BI-METAL	BI-METAL
320	10	8-10	UP TO 25	8-10	45	BI-METAL	BI-METAL
325	10	8-10	UP TO 25	8-10	45	BI-METAL	BI-METAL
330	10	8-10	UP TO 25	8-10	45	BI-METAL	BI-METAL
335	10	8-10	UP TO 25	8-10	45	BI-METAL	BI-METAL
340	10	8-10	UP TO 25	8-10	45	BI-METAL	BI-METAL
345	10	8-10	UP TO 25	8-10	45	BI-METAL	BI-METAL
350	10	8-10	UP TO 25	8-10	45	BI-METAL	BI-METAL
355	10	8-10	UP TO 25	8-10	45	BI-METAL	BI-METAL
360	10	8-10	UP TO 25	8-10	45	BI-METAL	BI-METAL
365	10	8-10	UP TO 25	8-10	45	BI-METAL	BI-METAL
370	10	8-10	UP TO 25	8-10	45	BI-METAL	BI-METAL
375	10	8-10	UP TO 25	8-10	45	BI-METAL	BI-METAL
380	10	8-10	UP TO 25	8-10	45	BI-METAL	BI-METAL
385	10	8-10	UP TO 25	8-10	45	BI-METAL	BI-METAL
390	10	8-10	UP TO 25	8-10	45	BI-METAL	BI-METAL
395	10	8-10	UP TO 25	8-10	45	BI-METAL	BI-METAL
400	10	8-10	UP TO 25	8-10	45	BI-METAL	BI-METAL
405	10	8-10	UP TO 25	8-10	45	BI-METAL	BI-METAL
410	10	8-10	UP TO 25	8-10	45	BI-METAL	BI-METAL
415	10	8-10	UP TO 25	8-10	45	BI-METAL	BI-METAL
420	10	8-10	UP TO 25	8-10	45	BI-METAL	BI-METAL
425	10	8-10	UP TO 25	8-10	45	BI-METAL	BI-METAL
430	10	8-10	UP TO 25	8-10	45	BI-METAL	BI-METAL
435	10	8-10	UP TO 25	8-10	45	BI-METAL	BI-METAL
440	10	8-10	UP TO 25	8-10	45	BI-METAL	BI-METAL
445	10	8-10	UP TO 25	8-10	45	BI-METAL	BI-METAL
450	10	8-10	UP TO 25	8-10	45	BI-METAL	BI-METAL
455	10	8-10	UP TO 25	8-10	45	BI-METAL	BI-METAL
460	10	8-10	UP TO 25	8-10	45	BI-METAL	BI-METAL
465	10	8-10	UP TO 25	8-10	45	BI-METAL	BI-METAL
470	10	8-10	UP TO 25	8-10	45	BI-METAL	BI-METAL
475	10	8-10	UP TO 25	8-10	45	BI-METAL	BI-METAL
480	10	8-10	UP TO 25	8-10	45	BI-METAL	BI-METAL
485	10	8-10	UP TO 25	8-10	45	BI-METAL	BI-METAL
490	10	8-10	UP TO 25	8-10	45	BI-METAL	BI-METAL
495	10	8-10	UP TO 25	8-10	45	BI-METAL	BI-METAL
500	10	8-10	UP TO 25	8-10	45	BI-METAL	BI-METAL

WHEN CUTTING STEEL CONTAINING MORE THAN ONE ALLOW, USE LOWEST SPEED RECOMMENDED FOR ANY TIME COMPONENT.

Job Selector.

CONTROL PANEL (Continued...)

3. **Light.** The optional worklight on some machines have this switch that turns the worklight "off" or "on". The worklight now has a "on-off" switch mounted directly on the light.
4. **Coolant.** Four (4) position selector switch with "aux", "off", "band on", and "on" settings.
 - (a) "Band on" allows the flood coolant system to operate when the band drive motor is running; (b) "on" allows the flood coolant system to operate without the band drive motor running; (c) "aux" is used for the optional cutting lubrication system; (d) "Off" turns off either system.
5. **Feed Force.** Turning this knob regulates the pressure being applied by the saw head and saw band against the stock being cut. Turn the knob **counter-clockwise** to "increase" the feed force, **clockwise** to "decrease" it.
6. **Head.** This selector has "feed" and "hold" settings. When downward saw head movement is desired, turn the selector to "feed". When no saw head movement is desired, turn the selector to "hold".

The following controls are for optional equipment. These options are described in the "Accessories" section later in this manual.

7. **Head Up.** Pushing this button will cause the saw head to raise.
8. **Variable Vise Pressure.** Use this control to regulate vise clamping force against materials which cannot tolerate full vise clamping pressure (such as thin-walled tubing, pipe, light structurals, etc.). To operate: (a) Pull the knob up; (b) Turn the knob **clockwise** to "increase" vise pressure, **counter-clockwise** to "decrease" it.
9. **Vise.** This selector has "open" and "clamp" settings. Pull the selector out to "open" the movable vise jaw, push it in to "clamp" the vise.
10. **Full Cycle Option.** This option and its controls are described in the "Accessories" section in this manual.

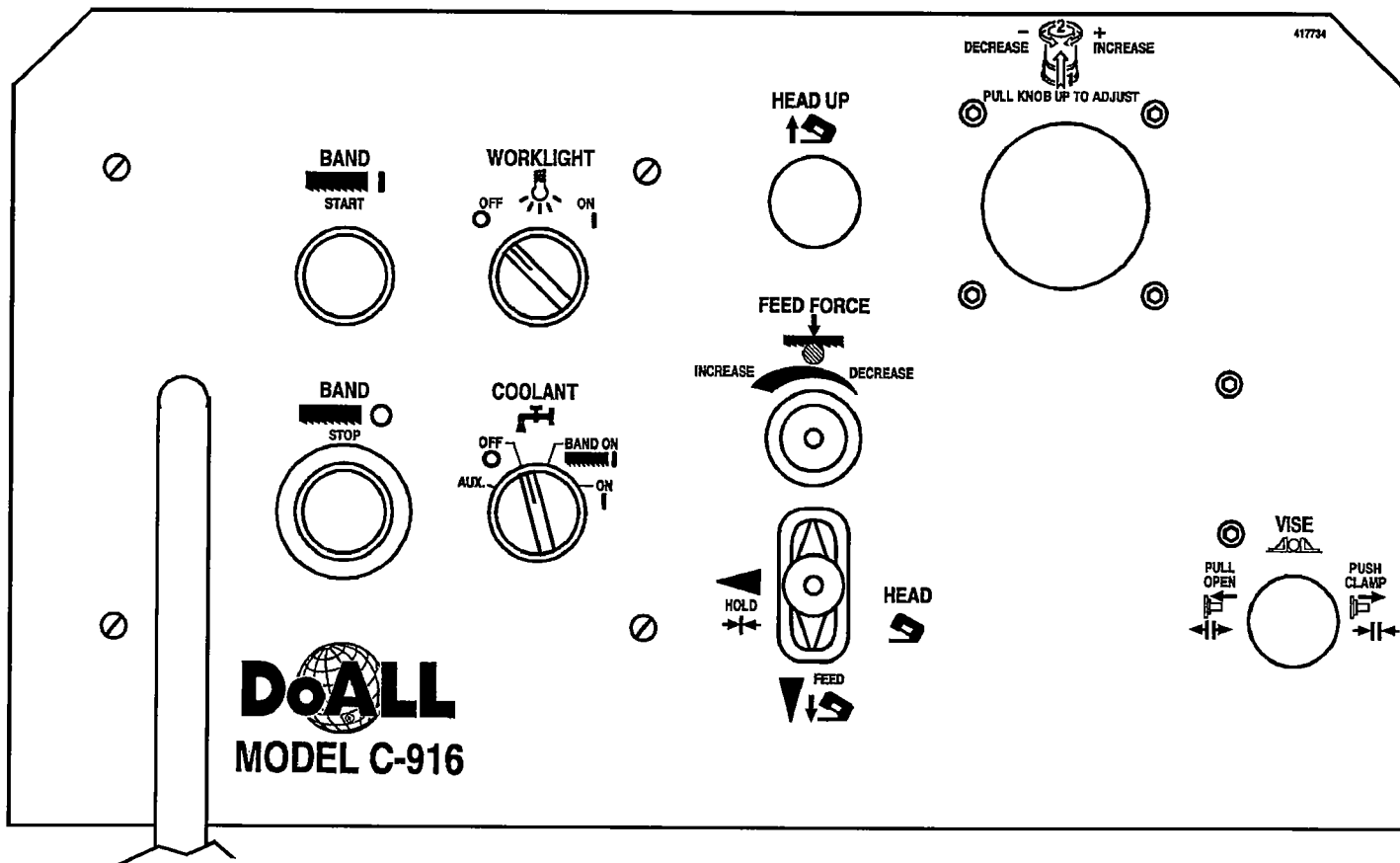

Typical Control Panel.

SAW BAND PREPARATION

Recommended Saw Band

1. The machine is shipped with an Imperial Bi-Metal Super Silencer saw band installed. Saw bands recommended for use with the machine should be 158 inches (4013 mm) long, one (1) inch (25 mm) wide, and have a 0.035 inch (0.89 mm) gage thickness.

Blade Guards

1. The following blade guards are positioned to provide operator safety while the machine is running: **(a)** A top guard located above and between the bandwheel doors; **(b)** Two (2) guards mounted between the lower left saw guide arm and the left bandwheel door; **(c)** A guard between the lower right saw guide arm and the right bandwheel door. **Blade guards (b) and (c) can be removed to facilitate saw band changing procedures.**



DO NOT defeat their purpose by operating the machine without these guards attached.

Saw Guide Insert Adjustment

1. Adjustment screws for the saw guide inserts are located on the lower portion of each saw guide arm.
2. Follow these adjustment procedures: **(a)** Turn the adjustment screw **clockwise** until tight against the saw band (**do not over tighten**); **(b)** Turn each adjustment screw back **counterclockwise** 1/4 to 1/2 turn.

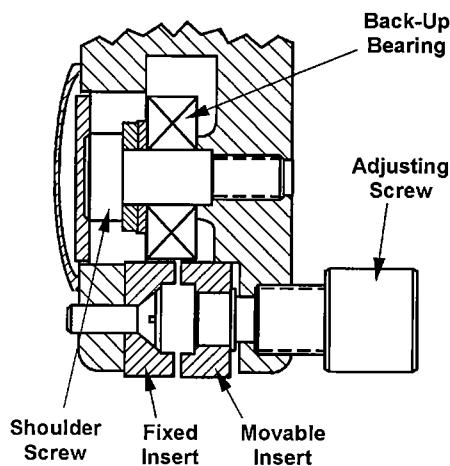

Saw Guide Detail.

Saw Band Removal



Always use extreme care when handling saw bands.

1. Push the **Band Stop** button. Then: **(a)** Turn the band tension handwheel **counterclockwise** (this moves the idler bandwheel to the right and loosens band tension); **(b)** Turn the **Head** control knob **counterclockwise** to the "hold" setting; **(c)** Grasp the band tension handwheel and lift the saw head to a position where there is space under the saw guide arms (approximately five (5) inches (125 mm)).
2. Open the right and left bandwheel doors. Then: **(a)** Remove or reposition the band brush, if necessary; **(b)** Loosen and remove the right and left blade guards; **(c)** Loosen the saw guide inserts by turning **counterclockwise**.
3. Place your gloved hand on the non-cutting edge of the saw band between the saw guide arms. Then: **(a)** Push the saw band downward to free it from the saw guide inserts; **(b)** Grasp the saw band near the idler bandwheel and remove it, then remove the saw band from around the drive bandwheel; **(c)** Move the saw band's upper strand down and under both saw guide arms.



Immediately dispose of the old or broken saw band. If possible, recoil the saw band into the original holder before scrapping it.

Saw Band Installation



Always use extreme care when handling saw bands.

1. Remove the old or broken saw band as described in the previous section. Clean metal chips and other foreign materials and debris from around the saw guides and both bandwheels.
2. Form the saw band into a loop. Then: **(a)** Slip the saw band under the saw guide arms and into approximate position for placement; **(b)** With the saw band's teeth facing towards you, slip the looped saw band around the drive and idler bandwheels.
3. Twist the saw band 90° so that its teeth between the saw guide arms point down and to the right. Then: **(a)** Insert the saw band into the saw guide inserts and pull up against the back-up bearing; **(c)** Check the saw band's position around the bandwheels (its back edge must rest against each bandwheel's rear flange).

SAW BAND PREPARATION (Continued...)

4. Apply correct band tension by turning the band tension handwheel **clockwise**. Then: **(a)** Remove the new saw band's protective cap; **(b)** Turn the saw guide insert adjustment screws **clockwise** until tight (**do not over tighten**); **(c)** Turn each adjustment screws back **counterclockwise** 1/4 to 1/2 turn. **(d)** Reposition or mount the band brush and blade guards; **(e)** Close and latch both bandwheel doors.

Band Tension Handwheel

1. Band tension is applied by turning the handwheel which protrudes from the saw head's left side. Turn the handwheel **clockwise** to increase band tension; **counterclockwise** to decrease it.

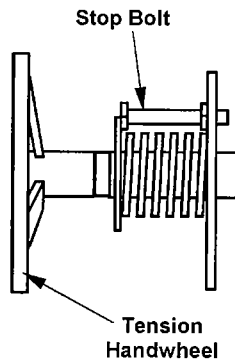

Turn Handwheel to Set Band Tension.

2. Correct band tension for the machine's standard one (1) inch (25.4 mm) wide by 0.035-inch (0.89 mm) gage saw band is 3.6 to 4.0 units measured by a Do-ALL Tensigage. This tension setting is established when the preset stop bolt contacts the large washer. An escutcheon near the band tension handwheel describes the washer to stop bolt relationship in a setting of 30,000 psi (2100 kg/cm²).
3. Suggested band tension settings are shown on the Job Selector. Important factors which influence band tension settings are the size of stock to be cut and desired band life. General rules-of-thumb are: **(a)** Lower tensions will increase saw band life; **(b)** Greater tension is required as spacing is increased between the saw guide arms; **(c)** Higher band speeds require greater tension.



DO NOT start the band drive motor unless the saw band has been properly tensioned.

BAND SPEED ADJUSTMENT



Change band speeds ONLY when the band drive motor is running. Be sure the saw band is correctly tensioned before starting the band drive motor.

1. Band speed is infinitely variable between 105 and 275 fpm (32 and 85 m/min) for 60 Hz machine; 90 and 230 fpm (27 and 70 m/min) for 50 Hz machines. To adjust, turn the band speed adjusting handwheel **clockwise** to "increase" band speed; **counterclockwise** to "decrease" it.

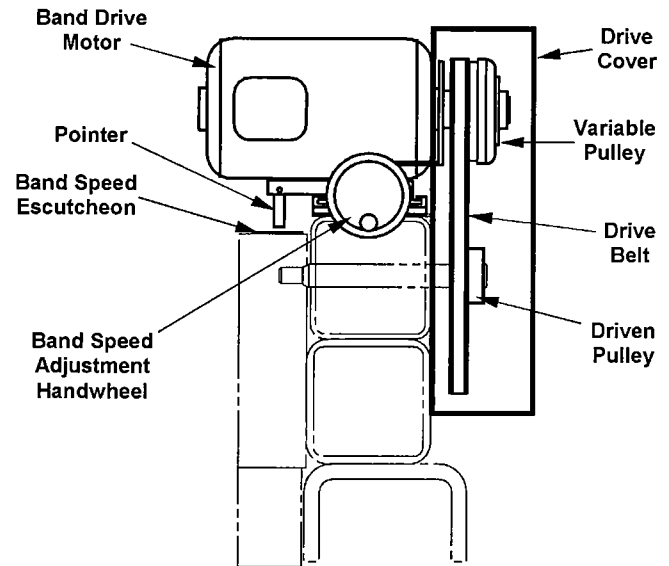

Band Drive Details.

2. Refer to the band speed escutcheon when setting or adjusting band speed.

SAW GUIDE ARM ADJUSTMENT

1. The machine's right saw guide arm is fixed. The left saw guide arm can be adjusted as follows to accommodate varying stock widths: **(a)** Loosen the saw guide insert adjustment screw by turning **counterclockwise**; **(b)** Loosen the left arm's locking knob by turning it **counterclockwise**; **(c)** Move the arm along the slide bar until it is as close as possible to the stock; **(c)** Turn the locking knob **clockwise** to tighten; **(e)** Tighten the insert adjustment screw as previously instructed.



DO NOT move the left saw guide arm while the saw band is running.

2. The best cutting results are generally obtained when the saw guide arms are positioned as close as possible to the stock.

HEAD FEED ADJUSTMENT

1. The **Feed Force** knob regulates the amount of pressure being exerted by the falling saw head against the stock.
2. When preparing to cut a piece of stock, turn the **Head selector** to "hold". Then: **(a)** Grasp the band tension handwheel and lift the saw head so it clears the stock; **(b)** Position the stock for a cut.

HEAD FEED ADJUSTMENT (Continued....)

3. Start the saw head's downward movement by pushing the **Band Start** button. Then: **(a)** Turn the **Head selector** to the "feed" setting (turn **counterclockwise**); **(b)** Gradually turn the **Feed Force** knob until the desired rate is obtained.

WISE JAW ADJUSTMENT

1. The distance between the movable (left) and fixed (right) vise jaws can be adjusted to accommodate varying stock widths. To adjust: **(a)** Lift the pawl arm attached to the movable vise jaw from the rack; **(b)** Slide the pawl arm and movable vise jaw in the desired direction until the jaw contacts the positioned stock, or the opening between the vise jaws is judged sufficient; **(c)** Lower the pawl arm so its protruding end segment engages into the nearest rack notch.

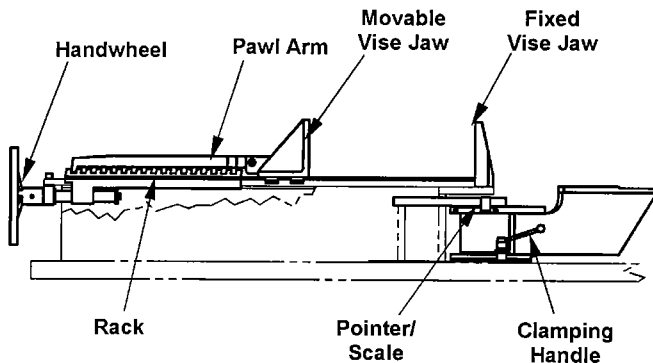

Pivot Vise Jaws.

2. Use the vise clamp adjustment handwheel (lower handwheel on the left side of the machine) to tighten the vise jaws securely. Turn the handwheel **clockwise** to tighten the vise jaws, **counterclockwise** to loosen the jaws.

SAW HEAD POSITIONING FOR ANGLE CUTS

1. To position the saw head for angle cutting from 0° to 45°: **(a)** Loosen the clamping handle by turning it **counterclockwise**; **(b)** Pivot the saw head to the desired angle as indicated by the pointer located just above the clamping handle; **(c)** Turn the clamping handle **clockwise** to lock the saw head in place.
2. The 0° and 45° angle positions have been preset at the factory. If adjustment becomes necessary, it can be made with the screws and jam nuts located on the rear of the pivot weldment.

3. To position the movable vise jaw: **(a)** Loosen both socket cap screws in the casting slots; **(b)** Lift the pawl arm and slide the vise jaw toward the fixed vise jaw; **(c)** Turn the movable vise jaw face until it butts against the fixed vise jaw face (both vises are thus positioned at the identical angle); **(d)** Tighten the cap screws; **(e)** Pull the pawl arm until there is sufficient space between the vise jaws to accommodate stock width; **(f)** Lower the pawl arm so its protruding end segment engages into the nearest rack notch; **(g)** Turn the vise clamping handwheel **clockwise** to tighten the vise jaws.
4. Make a crop cut to check angle accuracy.

COOLANT SELECTION AND APPLICATION

Coolant Selection

1. Choosing and using the proper cutting fluid is important to most cutting procedures. An operator's coolant choice will depend on such factors as: **(a)** The type of material being cut; **(b)** The material's machinability rating; **(c)** Band speed and feed rate to be used; **(d)** Saw band type to be used and its expected life; **(e)** The overall sawing operation.
2. When making a coolant choice, the operator will want to consider the following points:
 - Excessive heat build-up is the main cause of blade tooth failure during band machining. Coolant has both lubricating and cooling properties. Its application does the following: **(a)** Helps reduce the heat generated during sawing; **(b)** Helps prolong blade life; **(c)** Generally promotes more efficient cutting rates.
 - DoALL has developed several cutting fluids specifically for band machining. A DoALL Industrial Supply Center representative can provide complete information about all available coolant types and their recommended usages.
 - Using more than one (1) coolant variety may provide maximum sawing results and economy.

Coolant Application

1. Coolant is supplied by means of a reservoir and pump to the cutting area through the saw guide inserts on the left saw guide arm. Turn the valve **counterclockwise** until coolant completely covers both sides of the saw band.

COOLANT SELECTION AND APPLICATION (Continued...)

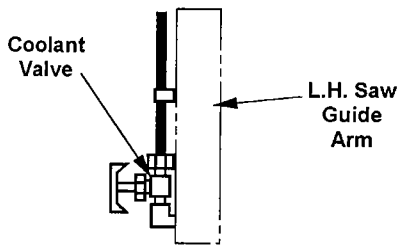

Coolant Valve on the Saw Guide Arm.

- Used coolant flows back to the reservoir through the return tube below the drive wheel. The screening and straining within the reservoir removes metal particles and other impurities before the coolant is recirculated.
- Coolant reservoir capacity is five (5) gallons (18.9 liters). The pump will not operate correctly unless it is completely submerged in coolant. Position the pump as close as shown in the illustration.

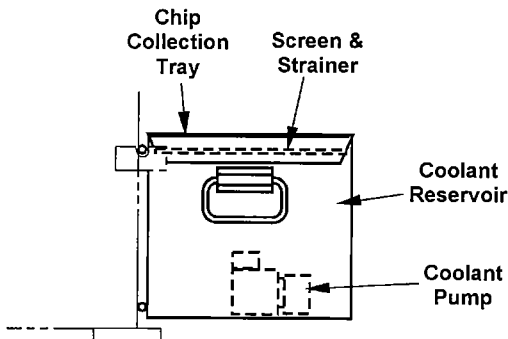

Coolant Reservoir.

- The brush must be properly adjusted to clean blade tooth gullets if satisfactory sawing performance is to be obtained. As bristles wear down, adjust brush position by: (a) Loosening the bolts holding the brush assembly to the bracket on the saw head; (b) Move the brush to the correct cleaning position; (c) Retightening the bracket bolts.

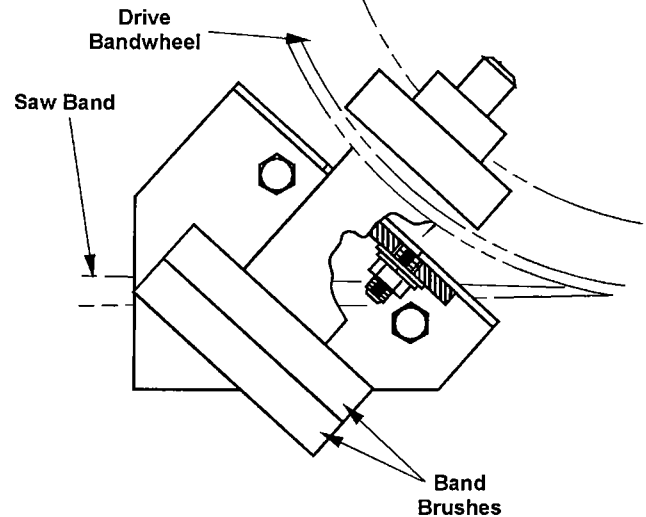

Band Brush.



NEVER adjust the band brush while the saw band is running.

Chip Removal

- Metal fragments removed from the band brush and from the stockpiece drop onto the chip pan. The chips flow with the coolant and drop into a strainer above the coolant reservoir compartment. Chip collections should be removed from the tray when necessary.
- In addition, the operator should check often for chip accumulations around such machine areas as: saw guides, vise bed, vise jaws, head feed cylinder, etc. These accumulations may affect machine performance if not removed. DoALL recommends removing chip accumulations at least twice per eight (8) hour shift and more often when necessary.
- Use the supplied shovel-rake to remove accumulated chips or other materials from the machine's operating areas.



Combination Shovel-Rake.



Be sure the band drive motor and the saw band are STOPPED completely before cleaning the machine.

DRY CUTTING

- The operator may find it desirable to cut some materials (such as cast iron, aluminum, magnesium, etc.) without coolant. When dry cutting these materials, follow the same operating procedures used when cutting with coolant.



Dry cutting will reduce saw band life.

BAND BRUSH AND CHIP REMOVAL

Band Brush

- A powered band brush removes metal particles from the saw blade teeth. The band brush is located in the right bandwheel cover (door). It is attached to a bracket that is mounted to the saw head frame.

TYPICAL OPERATION PROCEDURES

Preparation

1. These operations assume that the machine is prepared as follows: **(a)** The band drive motor is off; **(b)** The saw band is properly installed and tensioned; **(c)** Both bandwheel doors are closed; **(d)** All guards are in place and/or secured; **(e)** The coolant reservoir is full and all lubrication points are properly serviced; **(f)** The band brush is properly positioned; **(g)** The receiving tray (and roller stock conveyors if supplied) are properly positioned.

Loading Stock

1. Turn the **Head** control selector to "hold". Then: **(a)** Turn the **Feed Force** knob **clockwise** to its maximum position; **(b)** Grasp the band tension handwheel and lift the saw head until it clears the stock to be cut; **(c)** Adjust the movable saw guide arm for stock width; **(d)** Adjust the saw head for angle cutting if necessary; **(e)** Position the workstop (if supplied) at the desired location on the receiving tray; **(f)** Load stock onto the machine and secure it in cutting position by turning the vise jaw clamping handwheel.

Starting the Cut

1. Push the **Band Start** button. Then: **(a)** Turn the band speed adjustment handwheel until the pointer is at the desired velocity; **(b)** Start the saw head movement downward by turning the **Head** control selector to "feed"; **(c)** Turn the **Coolant** selector to "band on".
2. Turn on the **Coolant** valve located on the left saw guide arm so coolant flow covers both sides of the saw band (**counterclockwise** to "increase" coolant flow, **clockwise** to "decrease" it).
3. Turn the **Feed Force** knob until the desired cutting rate is established (**counterclockwise** to "increase" feed force, **clockwise** to "decrease" it). This setting can be adjusted as the cut progresses.
4. Adjust band speed, feed force, head fall, and coolant volume rates as necessary during the sawing process.

After a Cut is Completed

1. The machine will shut off with the saw head down following the completion of a cut. The operator should then: **(a)** Remove the cut-off piece; **(b)** Turn the **Head** control selector to "hold"; **(c)** Grasp the band tension handwheel and lift the saw head until it clears the stock; **(d)** Prepare for another cut or clean the machine if it is to remain idle for any period of time.



See the "Accessories" section for the optional Full Cycle operation procedures.

LUBRICATION

LUBRICATION CHART

LUBRICATION POINT NO.	LOCATION DESCRIPTION AND SERVICE RECOMMENDATIONS	LUBRICATION INTERVAL*	RECOMMENDED LUBRICANT
1	Head Feed Cylinder. 1 pint (0.47 liter) capacity. Check oil level if head fall rate is not uniform. Add oil if necessary.	CHECK 6 MONTHS/ CHANGE YEARLY	High quality, rust and oxidation-inhibited, medium hydraulic and general purpose oil. S.A.E. No. 40 ISO-VG Grade 46 (Formerly ASTM Grade No. 215). Union 76, UNAX RX , or equivalent.
2	Saw Guide Arm Slide. Clean and apply oil.	MONTHLY	High quality, rust and oxidation-inhibited, medium hydraulic and general purpose industrial oil. ISO-VG Grade 68 (Formerly ASTM Grade No. 315). Union 76, UNAX RX 68, or equivalent.
3	Head Pivot Shaft Bearing Surfaces. Apply oil.	MONTHLY	
4	Micellaneous: Vise Slide, Hinges, Pivot Points, etc. Clean and apply oil.	3 MONTHS	
5	Band Tension Screw. Clean and apply grease.	MONTHLY	Premium quality, multi-purpose lithium-base, EP (extreme pressure) grease. NLGI No. 2. Union 76, UNOBA EP 2, or equivalent.
6	Drive Motor Slide. Clean and apply grease.	3 MONTHS	
7	Drive Shaft Bearings. 2 grease fittings.	6 MONTHS	
8	Electric Motor. Drive.	Lubricate per manufacturer's recommendations.	
9	Coolant Reservoir. 5 gallon (18.9 liter) capacity. Drain, clean and refill as necessary.	AS REQUIRED	Premium quality, saw band coolant and lubricant. DoALL cutting fluids and/or oils.

* Lubrication intervals are based on a 8-hour day, 40-hour week.
Lubricate more often when required.

LUBRICATION DIAGRAM

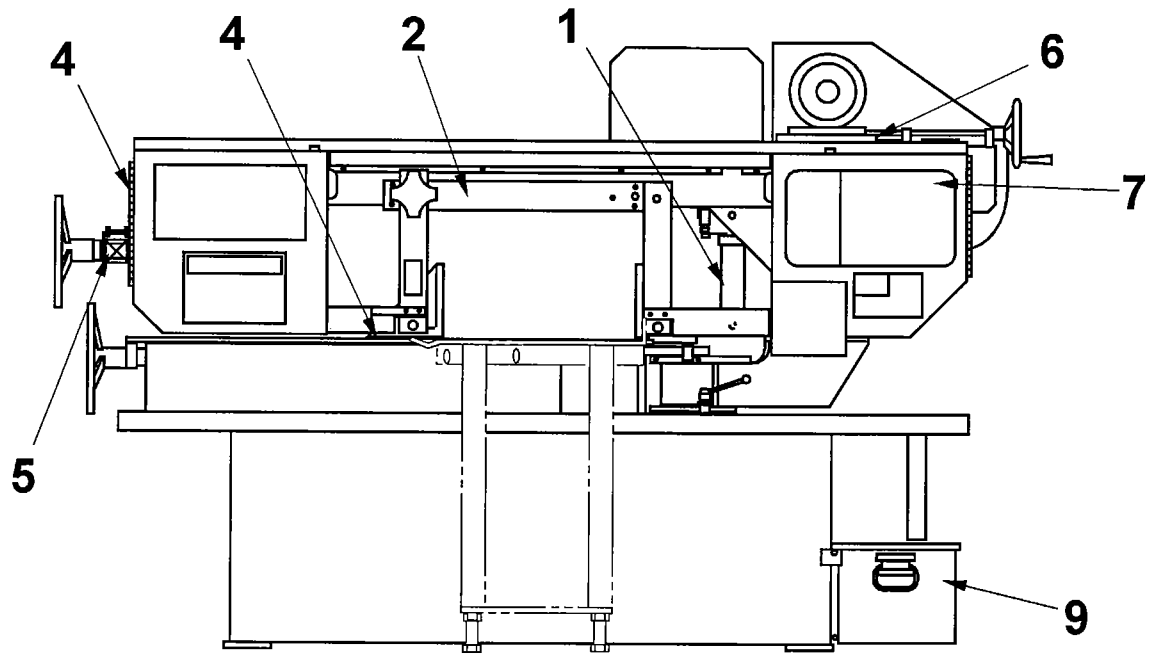

FRONT VIEW

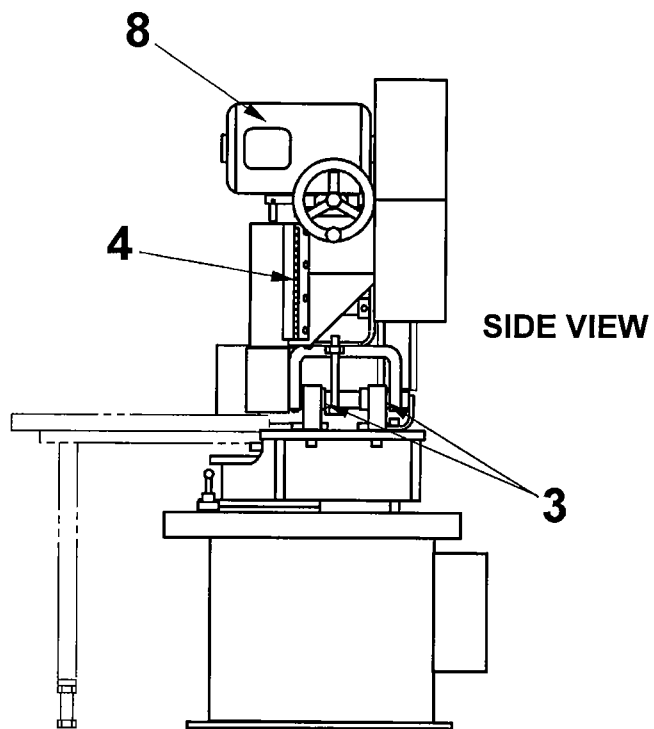

SIDE VIEW

MAINTENANCE

SAW GUIDE INSERT REPLACEMENT

1. The saw band should be removed to replace the saw guide inserts. See the "Operation" section for saw band removal procedures.
2. Remove the adjusting screw holding the spring washer housing and movable insert. Then: **(a)** Insert a screwdriver through the adjusting screw hole until it engages the fixed insert screw slot; **(b)** Remove the fixed insert; **(c)** Remove the retention screw located above the adjusting screw on the saw guide arm; **(d)** Remove the two (2) ball bearings from their seat.

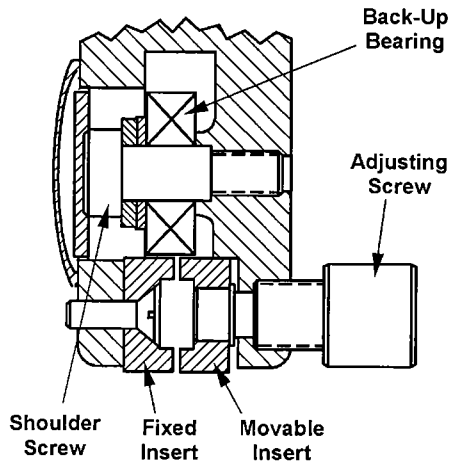

Saw Guide Detail.

2. Thoroughly clean the saw guide body and insert areas.
3. Inspect the roller bearing's two (2) useable wear surfaces. If the surface last used is worn: **(a)** Reinsert the bearing into the saw guide with the unworn surface exposed to the back of the saw band; **(b)** Reinstall the two (2) ball bearings; **(c)** Reinsert the retention screw.
4. Install new fixed and movable inserts if worn.
5. To reassemble: **(a)** Install the fixed and movable inserts, plus spring washer housing; **(b)** Tighten the adjusting screw until its tight (**do not over tighten**); **(c)** Place the saw band between the inserts and follow the saw band installation procedures covered in the "Operation" section; **(d)** Turn each adjustment screw back **counterclockwise** 1/4 to 1/2 turn.

DRIVE BELT REMOVAL OR REPLACEMENT

To install or remove the band drive belt:

1. Turn the machine off. Then: **(a)** Turn the band speed handwheel **clockwise** as far as possible; **(b)** Take off the drive cover by removing the screws holding it to the cover's back-up plate.
2. Slip the old drive belt from around the driven pulley, then from around the variable speed pulley. Next: **(a)** Carefully place a new drive belt into the drive pulley groove; **(b)** Pull the belt around and into the variable speed pulley groove.
3. Check the new belt's tracking in the pulley grooves by turning the band speed handwheel **slowly clockwise**. If tracking is correct, replace the drive cover.

BAND TENSION ADJUSTMENT

1. Tension adjustment of the saw band will be necessary from time to time. Adjustment is made by turning the upper handwheel extending from the machine's left side.
2. Correct band tension will stress a high-speed steel saw band to 30,000 psi (2100 kg/cm²). This is comparable to a DoALL Tensigage reading of "3.6" to "4". Refer also to the band tensioning portion of the Operation section of this manual.

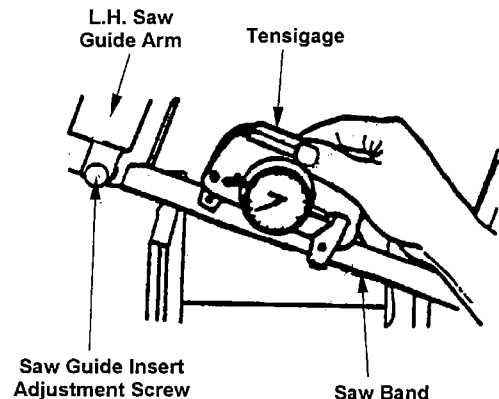

Using a DoALL Tensigage to Measure Band Tension.

COOLANT SYSTEM

1. Check the coolant often for signs of contamination or breakdown. Drain the entire system and clean it thoroughly when coolant becomes unsuitable for further use.
2. Empty the reservoir periodically and clean the coolant screens.

COOLANT SYSTEM (Continued....)

3. Flush the entire coolant system with DoALL's "Kleen Flush" when changing types of coolant used.

CHIP REMOVAL

Band Brush

1. The band chip brush should be positioned so that its bristles remove all metal chips from the blade tooth gullets, but do not touch the bottom of the gullets. Replace the brush if its bristles become too worn for proper blade cleaning. **DoALL replacement chip brushes are recommended.**
2. To replace the brush or adjust it to a new position: **(a)** Loosen the bracket screws; **(b)** Replace the brush or move it toward the saw band; **(c)** Tighten the bracket.

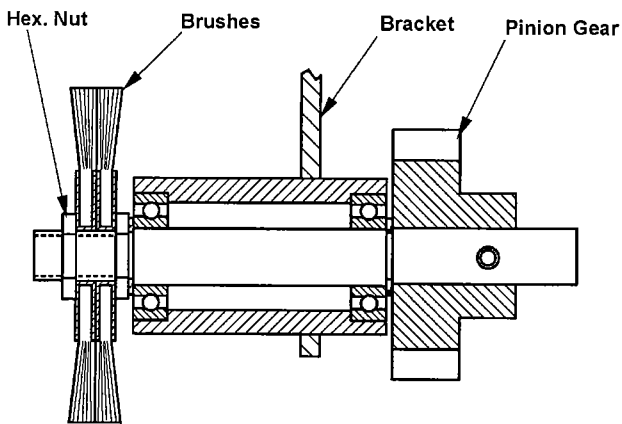

Band Brush.

Chip Collection Tray

1. Most metal chips removed from the saw band and from the stock drop onto the base and into the collection tray of the coolant reservoir at the machine's lower right side.
2. Remove this tray often to dispose of collected chips. Clean the coolant screens before reinserting the tray.

Machine Cleaning

1. During the sawing process, metal chips will accumulate below the band brush. These accumulations can affect machine performance and accuracy and should be removed as often as possible. **DoALL recommends removing chips at least twice per each eight (8) hour shift; more often when necessary.**

2. The supplied shovel-rake can be used to remove chip accumulations and other materials from the machine's operating areas.



Be sure the band drive motor and the saw band are STOPPED completely before cleaning the machine.

REPLACING VISE BED WEAR PLATES

1. The machine's vise bed is covered by steel plates. These must be replaced before their mounting screw heads become worn and damaged (making removal difficult).
2. The vise bed is covered by two (2) plates which can be removed when the movable vise jaw is at the maximum open position.
3. Follow these vise bed replacement directions: (a) Slide the movable vise jaw to its maximum open position; (b) Remove all the wear plate mounting screws; (c) Install new wear plates and mounting screws.

BANDWHEELS

1. Remove the bandwheels every six (6) months to clean them and the surrounding machine areas.
2. Occasionally check each bandwheel's back-up flange and wheel tread for wear. Saw bands will not track properly if the wheel tread's taper is worn.

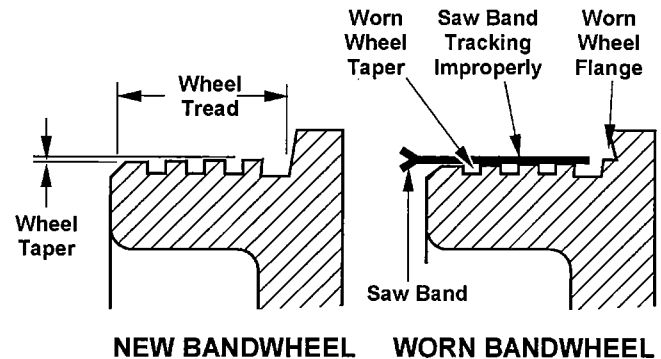

Bandwheel Flange and Tread.

HEAD FEED CYLINDER

1. Oil replenishment and/or air bleeding may be necessary over a period of time (such as replacement of the cylinder). This can be accomplished without removing the cylinder from the machine. Follow these procedures:

HEAD FEED CYLINDER (Continued....)

- Raise the saw head enough to remove the pipe plug from the cylinder's top end cap. Then: **(a)** Return the saw head to the down position; **(b)** **Slowly** pour hydraulic oil (see the Lubrication Chart for recommended oils) into the open port until overflow occurs; **(c)** Replace the pipe plug and turn the **Feed Force** knob counterclockwise to the maximum.
- Raise and lower the saw head to its maximum limits several times. Then: **(a)** Once more remove the pipe plug; **(b)** **Slowly** pour hydraulic oil into the open port until overflow occurs (this should be done with the piston rod fully retracted); **(c)** Repeat this process several times, if necessary, to purge excess air from the cylinder.
- With the **Feed Force** valve shut off, the piston should not sag more than 1/4 inch (6.3 mm) when the handwheel is released after full saw head raise and full extension of the head feed cylinder piston rod (measure the sag or piston rod retraction at the piston rod).

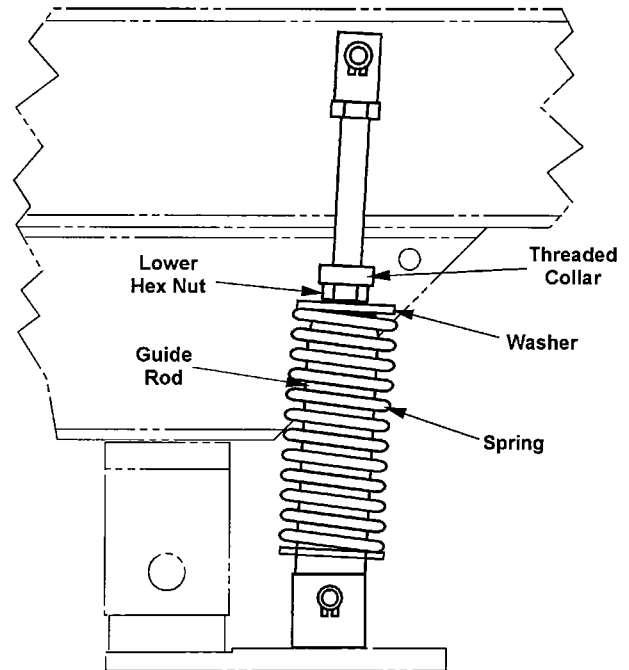

Counterbalance Spring.

COUNTERBALANCE SPRING

1. After a period of time, the saw head may not cut through the stock or cuts too far into the receiving tray. To adjust, follow these procedures:
- There is no need to remove the counterbalance spring from the machine. **(a)** Loosen the threaded collar from the lower hex nut; **(b)** Adjust the lower hex nut up or down until the saw band teeth are approximately 0.06 inch (1.5 mm) below the work surface; **(c)** Turn the threaded collar down tightly on top of the hex nut and secure it.



Be sure the saw head falls only enough to cut completely through the work. TOO MUCH head fall could result in cutting the receiving tray too deeply or completely off. TOO LITTLE head fall will result in an incomplete cut through the workpiece.

TROUBLE SHOOTING



Repair and adjustment procedures should be made only by experienced maintenance personnel, or by a DoALL Industrial Supply Center service representative. Reference to the machine's electrical and hydraulic schematics will be helpful.

MACHINE WON'T START

1. Overload relays are tripped. Wait several minutes for them to cool, then reset.
2. Make sure both bandwheel doors are closed.
3. Check for broken belts and/or mechanical jamming.
4. Raise the saw head off the head down limit switch.
5. Check for a burned out band drive motor.
6. Check the incoming leads, fuses, wiring, and control circuit fuse for possible malfunction.

SAW BAND RUNS IN WRONG DIRECTION

1. Switch the incoming electrical starter lines.

MACHINE STARTS, BUT WON'T CONTINUE RUNNING

1. Check for defective band drive contactor in the electrical control box.

INACCURATE CUT-OFF

1. Saw band teeth are dull or worn.
2. The chip brush needs adjustment or replacement.
3. Increase the band speed or decrease the feed rate.
4. Check for dirty coolant. Replace if necessary.
5. Coolant is not being supplied evenly to both sides of the saw band.
6. Stock is crooked. This usually results in straight, but not square cuts.
7. Decrease the distance between the saw guide arms. Move the left arm as close as possible to the stock being cut.

8. Check for incorrect blade pitch being used.
9. Band tension is incorrect.
10. Check for incorrectly adjusted saw guide inserts and back-up bearing.
11. Check for machine misalignment (have a DoALL Industrial Supply Center service representative check and/or adjust machine alignment).
12. Tighten the workstop (if supplied) clamping knob.

VERTICAL CUT INACCURACY (Cut pieces are thicker at the top or bottom)

1. Check for loose or worn saw guide inserts. Tighten the inserts if loose, replace inserts if worn.
2. Reduce the feed rate being used.
3. Check for crooked stock and/or incorrect stock positioning between the vise jaws.
4. Move the left saw guide arm closer to the stock.
5. Check for incorrect band tension adjustment.
6. Check for a worn saw band.
7. Check for saw head vertical misalignment. Have a DoALL Industrial Supply Center service representative check and/or adjust saw head alignment.

HORIZONTAL CUT INACCURACY (Cut pieces are thicker on one side)

1. Check for loose or worn saw guide inserts. Tighten the inserts if loose, replace inserts if worn.
2. Check for crooked stock and/or incorrect stock positioning between the vise jaws.
3. Check for machine misalignment. Have a DoALL Industrial Supply Center service representative check and/or adjust machine alignment.

BAND TEETH STRIPPING

1. Increase the band speed or decrease the feed rate.
2. Check for chip welding, or for a chipped blade tooth lodged in the cut.

TROUBLE SHOOTING (Continued....)

6. Check for vibration caused by stock not being held firmly between the vise jaws.
7. Check for worn saw guide inserts and/or back-up bearing.
8. Coolant is not adequately covering both sides of the saw band.
9. Check for incorrect band tension.
10. Check for an improperly adjusted saw head counterbalance spring.

PREMATURE SAW BAND BREAKAGE

1. Check for a poor weld in the saw band, or for incorrect band tension.
2. Saw band is being dropped into the stock. Make an adjustment with the **Feed Force** Control .
3. Increase the band speed and/or decrease the feed rate.
4. Stock is not being held firmly between the vise jaws.
5. Check for improper adjustment of the saw guide inserts and back-up bearing.
6. Install a finer pitch saw band.
7. Increase the coolant volume being supplied.

BAND TOOTH GULLETS LOADING

1. Use a courser pitch saw band.
2. Increase the band speed or decrease the feed rate.
3. Band brush needs adjustment or replacement.
4. Check for incorrect coolant application.
5. Check for incorrect band tension adjustment.

PREMATURE BAND TEETH DULLING

1. Band speed and/or cutting rate is too high.
2. Check for faulty stock: heavy scale, inclusions, hard spots, etc.
3. Stock analysis is incorrect. This can result in the wrong initial cutting recommendations.

4. Check for coolant not covering the saw band completely.
5. Check for saw band vibration or chip welding.
6. Check for a chipped blade tooth lodged in the cut.
7. Incorrect saw band is being used.
8. Check for incorrect band tension adjustment.
9. Incorrect coolant is being used, or the mixture is too weak.
10. Decrease the feed rate during the first few cuts to break-in the saw band if new.

SAW BAND STALLS DURING A CUT

1. Decrease the feed rate or increase the band speed.
2. Check for incorrect band tension adjustment.
3. Use a finer pitch blade -- at least three (3) teeth should be in the stock at all times.
4. Check for a worn or slipping drive motor belt.

SAW BAND VIBRATION (While Sawing)

1. Check for incorrect blade pitch choice.
2. Band speed being used is incorrect.
3. Check for a loose left saw guide arm.
4. Coolant choice is incorrect, or the mixture is too weak.
5. Make a saw head feed rate adjustment.
6. Stock is not held firmly between the vise jaws.
7. Check for worn or improperly adjusted saw guide inserts.
8. Check for a worn saw guide back-up bearing.
9. Check for a dull or damaged saw band.
10. Check for incorrect band tension adjustment.

TROUBLE SHOOTING (Continued....)

SAW BAND NOT RUNNING TRUE AGAINST SAW GUIDE BACK-UP BEARINGS (Vibration may result)

1. Check for chipped or worn back-up bearings. Replace if chipped or worn more than 0.020-inch (0.5 mm).
2. Check for loose saw guide arms, or arms are not located close enough to the stock.
3. Check machine alignment (Call a DoALL Industrial Supply Center service representative).

HIGH FREQUENCY SQUEAL DEVELOPS WHILE SAWING

1. Increase the feed rate (rate being used is not compatible with th size or type of material being cut).
2. Increase the coolant volume.
3. Use a courser pitch saw band.
4. Reduce or vary the band speed.
5. Check the band tension setting.

CUT-OFF PIECE SURFACE FINISH IS TOO ROUGH

1. Check for machine or saw band vibration.
2. Check for a dull or damaged saw band.
3. Use a finer pitch saw blade.
4. Check for worn saw guide back-up bearings. Replace if necessary.
5. Band tension setting is incorrect.
6. Increase the band speed or decrease the feed rate.
7. Check for incorrect coolant type being used.

CUTTING RATE IS TOO SLOW

1. Use a courser pitch saw blade.
2. Increase the band speed or feed rate.

NO COOLANT FLOW

1. Check for low coolant level in the reservoir.

2. Remove the coolant volume control valve and hose. Then use an air hose to clean out both units.
3. Clean the coolant pump intake screen.
4. Check for coolant pump failure.
5. Check for a faulty coolant pump fuse.

SAW HEAD WON'T RAISE, OR RAISES SLOWLY

1. Check for mechanical obstructions.
2. Check for low air system pressure. Pressure should be between 85 - 90 psi (5.8 - 6.3 bar).

SAW HEAD WON'T LOWER

1. The feed rate is too low.
2. Check for saw head obstructions.

SAW HEAD LOWERS ERRATICALLY

1. Check for mechanical obstruction or binding.
2. Check for worn or damaged head feed cylinder or head feed valve.
3. Check for air in the head feed cylinder.

SAW HEAD DROPS SLOWLY WHEN MACHINE IS SHUT OFF

1. Check for a worn head feed cylinder.
2. Check for faulty head feed control valve leakage.

INCOMPLETE CUT

1. Clear away build-up of chips or other debris on the vise bed (check also for build-up below the saw guides).
2. Check the counterbalance spring adjustment.

ACCESSORIES

ROLLER STOCK CONVEYORS

- Your machine may be equipped with one of the following roller stock conveyors for moving long stock into cutting position (or as an unloading adjunct). The following conveyors are available:
 - Stock conveyor five (5) feet (1524.0 mm) long by 20 inches (508.0 mm) wide with a weight capacity of 750 pounds (340.2 kg) per roller.
 - Stock conveyor ten (10) feet (3048.0 mm) long by 20 inches (508.0 mm) wide with a weight capacity of 750 pounds (340.2 kg) per roller.

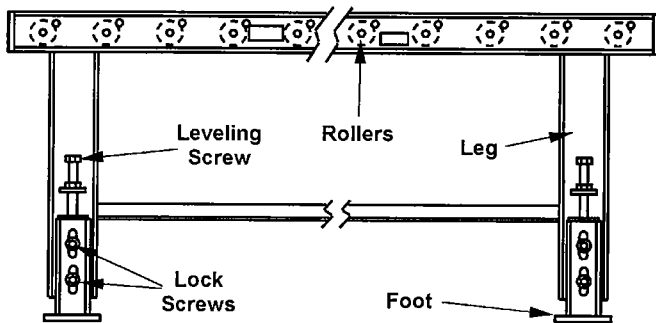

Roller Stock Conveyor.

- To install a stock conveyor: **(a)** Position conveyor behind the machine base; **(b)** Install the interface plate to the machine base using the hardware provided. **(c)** Bolt the conveyor to the interface plate with hardware provided. Do **not** tighten hardware at this time.

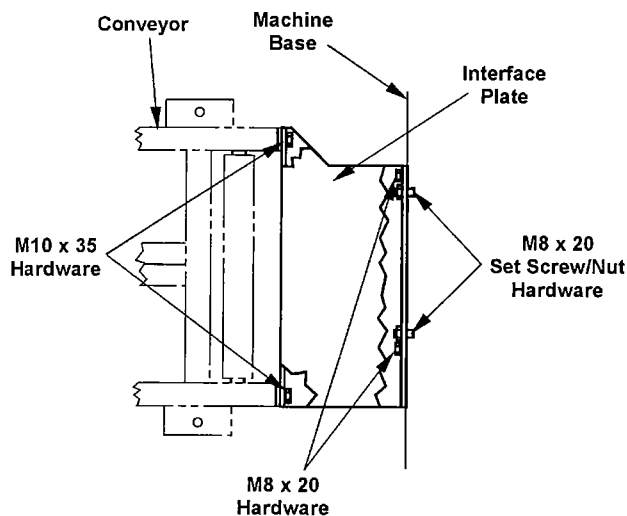

Interface Plate Installation.

- Adjust the conveyor to the machine with the leveling screws on the conveyor legs. The forward conveyor roller should be inline to 0.010-inch (0.25 mm) above the vise bed wear plate. The remaining rollers should be within 0.010 inch (0.25 mm) per 24 inches (609.6 mm) of travel.
- Tighten all hardware once adjustments have been made.
- Depress the roller shafts for ease of installation or removal of rollers.



Anchor the conveyor to the floor after all leveling and adjustments are made.

VERTICAL GUIDE ROLLERS

- Vertical guide rollers are effectively used to help maintain correct positioning of long stock on the conveyor.
- These can be installed between the interface plate and conveyor or between conveyors (if more than one is supplied).

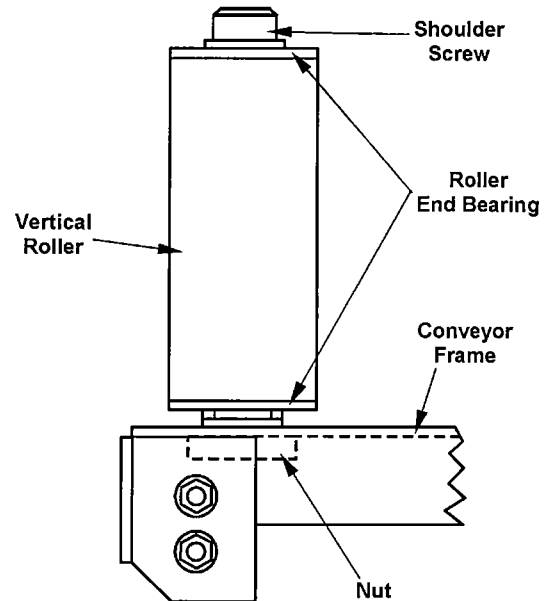

Vertical Guide Roller.

PNEUMATIC HEAD LIFT

- This option includes an air cylinder with all of the necessary mounting hardware and controls. The cylinder mounts on machine base and head beam. Plant air supply at 80 to 90 psi (5.62 to 6.33 kg/cm²) is required to operate this option.

PNEUMATIC HEAD LIFT (Continued...)



DO NOT exceed 90 psi (6.33 kg/cm²) air pressure.

- When this option is supplied, a new control appears on the control panel. Push the **Head Up** button to raise the saw head after completion of a cut.
- A flow control valve located on the bottom port of the air cylinder regulates the saw head up speed. Turn the adjusting screw **counterclockwise** to "increase" the head up speed, **clockwise** to "decrease" it.

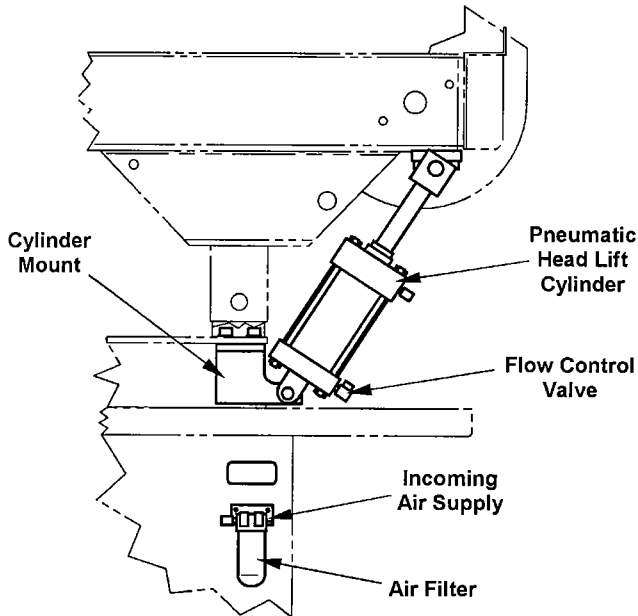

Pneumatic Head Lift Option.

- An approximate saw head raise time of one (1) to two (2) seconds is desirable (with a gentle cushioned effect at maximum head up position).



Individual machines may require slightly different adjustment to obtain the desired cushioned effect.

- To adjust the speed at which the saw head raises:
 - Turn the adjusting screw on the flow control valve of the air cylinder clockwise to close the valve completely, then give it one (1) **counterclockwise** turn;
 - With incoming pressure at 85 psi (6.0 kg/cm²), push the **Head Up** button on the control panel;
 - If the saw head raises too slowly, give the adjusting screw **counterclockwise** turns in 1/4 turn increments.
- Raise the saw head after each 1/4 turn until the desired head raise time and cushioned effect is achieved.



The flow control valve must not be adjusted so far counterclockwise that the cushioned effect at the maximum head up position is eliminated.

- If this option is not factory installed, follow the above adjustment procedures when raising the saw head for the first time.

BAND LUBRICATOR

- See the instructions sent with the unit for information on operation and adjustments.

PNEUMATIC VISE

- This option includes an air cylinder with all of the necessary mounting hardware and controls. The cylinder mounts to the movable vise jaw. Plant air supply at 80 to 90 psi (5.62 to 6.33 kg/cm²) is required to operate this option.



DO NOT exceed 90 psi (6.33 kg/cm²) air pressure.

- When this option is supplied, two (2) new controls appears on the control panel:
 - Vise.** This selector has "open" and "clamp" settings. Pull the selector out to "open" the movable vise jaw, push it in to "clamp" the vise.
 - Variable Vise Pressure.** Use this control to regulate vise clamping force against materials which cannot tolerate full vise clamping pressure (such as thin-walled tubing, pipe, light structurals, etc.) To operate: **(a)** Pull the knob up; **(b)** Turn the knob **clockwise** to "increase" vise pressure, **counterclockwise** to "decrease" it.

FULL CYCLE OPTION

- This option allows the operator to select between manual and automatic operations.
- When this option is supplied, two (2) new controls appears on the control panel:

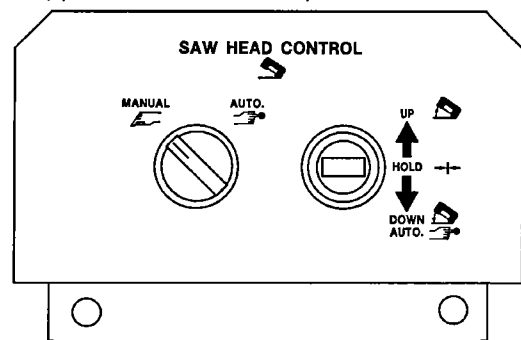

Full Cycle Control Panel.

FULL CYCLE OPTION (Continued....)

- **Manual - Auto.** This selector switch allows the operator to choose between manual or full cycle machine operation. Turn the selector to "manual" for normal operation; "auto" for automatic operation of the full cycle.
- **Saw Head Control.** This selector switch has "up", "hold" and "down/auto" settings. Move the selector to "up" to raise the saw head; "hold" to hold the saw head at any position. The "down/auto" setting is used to lower the saw head and to allow operation in the automatic full cycle mode.

Manual Operation

1. Start the machine in the following conditions: **(a)** Band drive motor is off; **(b)** **Manual/Auto** selector at "manual"; **(c)** **Saw Head Control** selector at "hold".
2. With no stock between the vise jaws, proceed as follows: **(a)** Move the **Saw Head Control** selector to "down/auto" and allow the saw head to lower completely; **(b)** Move the head height stop pin (located in front of the head feed cylinder) to the desired work height position; **(c)** Raise the saw head completely by moving the **Saw Head Control** selector to "up". The saw head will raise until it reaches the stop.



If the saw head does not move when the Saw Head Control selector is moved from "hold" to "down/auto", move the selector from "hold" to "up" and then to "down/auto".

3. Locate the stock in desired cutting position and clamp it between the vise jaws. Push the **Band Start** button.
4. Move the **Saw Head Control** selector to "down/auto" to start the saw head's downward motion. Adjust the **Feed Force** knob as necessary as the saw head starts downward to make the cut. Move the selector to "hold" whenever you wish to stop saw head movement.

Full Cycle Operation

1. Use the "Manual Operation" instructions to position and clamp the stock.
2. Place the **Saw Head Control** selector at "hold" and move the **Manual/Auto** selector to "auto".

3. Push the **Band Start** button. Next: **(a)** Move the **Saw Head Control** selector to "down/auto"; **(b)** Adjust the **Feed Force** knob as necessary as the saw head starts downward to make the cut.
4. After the saw head has lowered completely, the band drive motor will shut off and the saw head will raise to the position determined by the stop pin.



During automatic operation, the cut may be interrupted whenever necessary by moving the Saw Head Control selector to the "hold" or "up" setting.

5. The operator can now remove the cut-off piece and position the stock for another cut.
6. After clamping the stock between the vise jaws, push the **Band Start** button. The next cut will now be made. This procedure may be followed as many times as needed.

OPTIONAL BAND SPEED

1. Machines with an optional band speed range between 70 and 180 fpm (21 and 55 m/min) are available from the factory upon special request.

FLUSHING HOSE

1. The flushing hose attaches to the coolant pump and delivers cutting fluid through a hand nozzle. It is used primarily for machine cleaning purposes.

WORKSTOP

1. This option proves helpful when several cuts of the same identical length are required. It can be adjusted for lengths from 0 to 18 inches (0 to 457.2 mm). The workstop attaches to the edge of the receiving tray.
- There is also an optional 48 inch (1219.2 mm) scale that replaces the 18 inch (457.2 mm) scale.

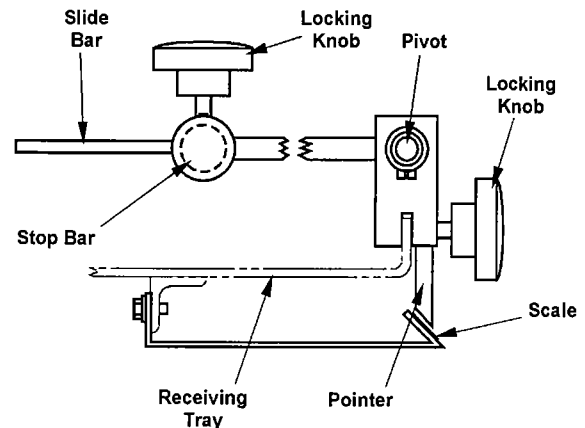

Workstop.

WORKSTOP (Continued....)

2. The workstop slides along the edge of the receiving tray, then is secured at the desired length indicated by a locking knob. The distance is indicated by a scale with an attached pointer. The slide bar also pivots so the stop bar can be positioned to contact the stock at various heights. When not in use, the stop bar can be positioned so it does not interfere with stock movement, or can easily be removed from the tray.
3. To position stock with the workstop for a cut: **(a)** Move the workstop along the receiving tray edge until the distance between the lowered saw band and lowered stop bar is indicated on the scale; **(b)** Tighten the locking knob to secure the stop bar; **(c)** Move the stock to be cut through the opened vise jaws until the stock contacts the lowered stop bar; **(d)** Clamp the vise jaws; **(e)** Proceed with the cutting operations.

IDLER WHEEL MOTION DETECTOR

1. This safety device located on the saw head plate behind the idler bandwheel stops the machine if the saw band should break or stall in the workpiece. Always determine the cause of the stoppage and correct it before attempting to resume operation.

WORKLIGHT

1. The worklight illuminates the cutting area for better visibility and safety. It has its own "on-off" switch mounted on the light.
- Some machines have a selector switch mounted on the control panel to turn the worklight "on" and "off".