

# Assessment of the quality of Indiana coal for Integrated Gasification Combined Cycle Performance (IGCC)

Progress report – June 2005

*M. Mastalerz, A. Drobniak, J. Rupp and N. Shaffer  
Indiana Geological Survey, Indiana University*

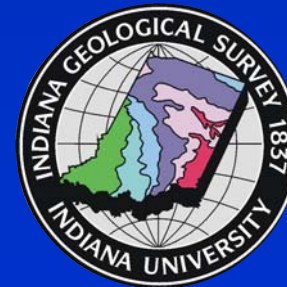

# PROJECT JUSTIFICATION

**Evaluating Indiana coals for IGCC is timely and important**

- **Indiana has significant coal reserves (~57 billion short tons, of which 17.5 billion tons is available for mining). 73% of coal produced in Indiana is used to generate electricity and more than 90% of electricity generated in Indiana comes from coal**
- **Burning Indiana coal causes serious environmental concerns because the majority of Indiana coals have high sulfur content**
- **Integrated Gasification Combined Cycle (IGCC), being one of Clean Coal Technologies, could help Indiana. IGCC can achieve 99% SO<sub>2</sub> removal, removing also Hg and CO<sub>2</sub> upstream of the combustion process**

# IGCC plant

## Gasification:

- 1) Volatile pyrolysis – fast volatilization and compound degradation;
- 2) Char gasification – slow process

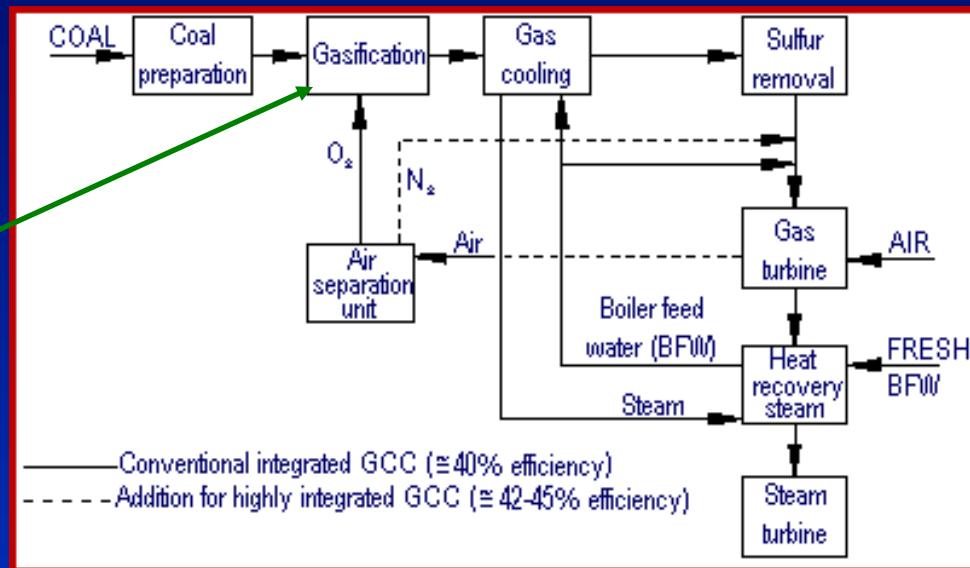

In the IGCC process, plants turn coal to gas, removing most of the sulfur dioxide and other emissions before the gas is used to fuel a combustion turbine generator. The hot gases are then used to heat steam, driving a steam turbine generator. In this technology, coal could be gasified in various ways, by properly controlling the mix of coal, oxygen, and steam within the gasifier.

## PROJECT OBJECTIVES

- 1. Identify coal properties that are important for IGCC and assess availability of these types of data for Indiana coal beds.**
- 2. Outline future research needed to assess performance of Indiana coal during gasification:**
  - a) Propose new laboratory analyses,**
  - b) Suggest strategy for modeling coal performance in IGCC units.**
- 3. Research and identify budgetary needs, time requirements, possible collaborations and sources of matching funds.**

# PROGRESS REPORT

**PROJECT DURATION: MARCH 1 – NOVEMBER 30, 2005**

<b>Tasks</b>	<b>Activity</b>	<b>Deadline</b>	<b>% completed</b>
<b>Task 1</b>	Identifying properties of major importance to IGCC performance of Indiana coals	April 30	100%
<b>Task 2</b>	Assessing availability of data on coal that are critical for IGCC	June 31	100%
<b>Task 3</b>	Identify areas in which more data are needed	August 31	10%
<b>Task 4</b>	Propose new research	November 30	0%

# Task 1:

**Identifying properties of major importance to IGCC performance of Indiana coals**

**Deadline: April 30**

**100% completed**

1. We performed intensive literature search on coal gasification from various sources and various countries. Based on the literature as well as our own research we have identified several parameters of coal quality that are very important for the performance in an IGCC system
2. We developed summary tables that show how these coal properties influence IGCC behavior and what the requirements are for three types of gasifiers: fixed-bed gasifier, **fluidized –bed gasifier, and entrained-flow gasifier .**

## Example of a summary table for entrained flow gasifiers.

Parameter	Importance	Coal Requirements
<b>Moisture</b>	<ul style="list-style-type: none"> <li>influences gasifier efficiency (higher moisture - lower efficiency)</li> </ul>	- A range of moisture contents are used
<b>Volatile matter</b>	<ul style="list-style-type: none"> <li>influences the extent and rate of gasification reactions</li> </ul>	- A range of volatile matter contents are used
<b>Heating value</b>	<ul style="list-style-type: none"> <li>determines plant dimensions</li> <li>influences generation capacity (higher heating value – higher capacity and efficiency)</li> </ul>	- A range of heating values are used
<b>Ash content</b>	<ul style="list-style-type: none"> <li>influences net cycle efficiency (higher ash –lower efficiency)</li> <li>influences flux addition rate</li> </ul>	<25%
<b>AFT (flow, reduction)</b>	<ul style="list-style-type: none"> <li>influence melting ability of discharged slag (it needs to be melted below performance temperature)</li> <li>influences operating costs (higher temperature– higher costs)</li> </ul>	<1500°C
<b>Slag viscosity</b>	viscosity must be sufficiently low to ensure smooth slag flow down the gasifier walls	<ul style="list-style-type: none"> <li>Preferred &lt;15Pa.s</li> <li>Used up to 25 Pa.s</li> </ul>
<b>Char reactivity</b>	<ul style="list-style-type: none"> <li>influence the extent of carbon conversion (higher reactivity – higher cycle efficiency)</li> <li>influences oxygen consumption</li> </ul>	- A range of reactivities can be used because of higher operational temperature
<b>Sulfur</b>	<ul style="list-style-type: none"> <li>can cause corrosion of heat exchanger surfaces</li> <li>influences operating costs (higher sulfur –higher costs)</li> </ul>	- Preferred S<1.5%
<b>Nitrogen</b>	<ul style="list-style-type: none"> <li>contributes to NO<sub>x</sub> emissions</li> </ul>	
<b>Chlorine</b>	<ul style="list-style-type: none"> <li>forming HCl can poison gas cleaning system catalysts</li> <li>HCl can cause chloride stress corrosion</li> </ul>	<0.4% (ad)

# Task 2:

Assessing availability of data on coal that are critical for IGCC

Deadline: June 31

100% completed

- A database in Microsoft Access format has been created.

	Moisture	Fixed C	Volatiles	Ash fusion temp.	Char reactivity	Slag viscosity
Danville	149	116	116	12	0	12
Hymera	119	102	102	0	0	0
Springfield	320	280	280	0	0	1
U. Block	120	76	76	11	0	10
L. Block	142	50	50	15	0	15

Good coverage

NO DATA

- Maps of selected parameters have been generated

# Ash yield (weight %, dry) of the Springfield Coal

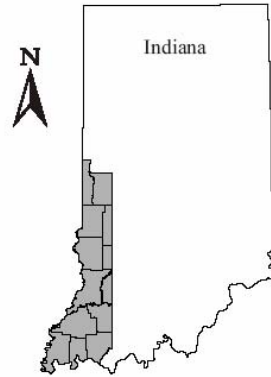

Map of southwestern Indiana showing the ash content (dry basis) of the Springfield coal.

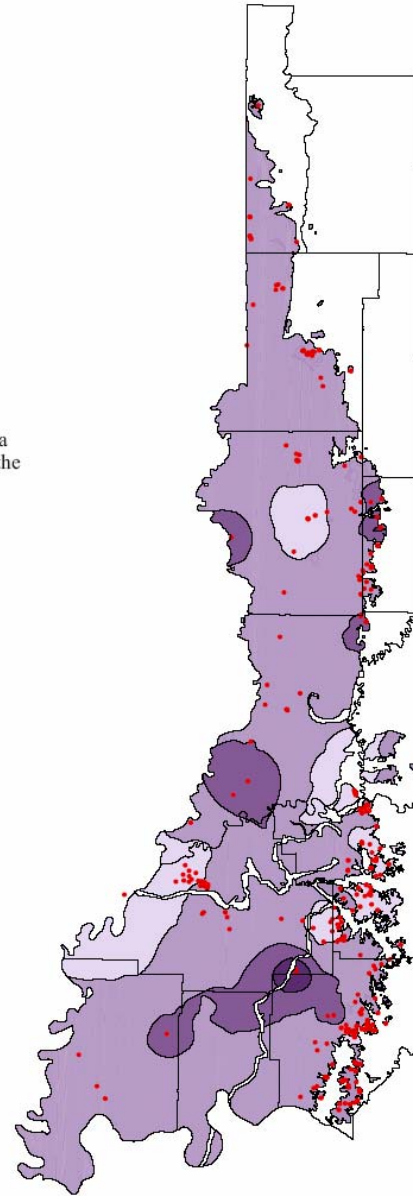
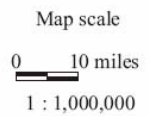
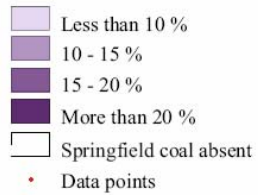

# Heating value (Btu/lb, dry) of the Danville Coal

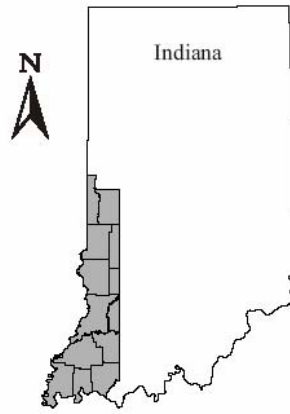

Map of southwestern Indiana showing the heating value (Btu/lb on dry basis) of the Danville coal.

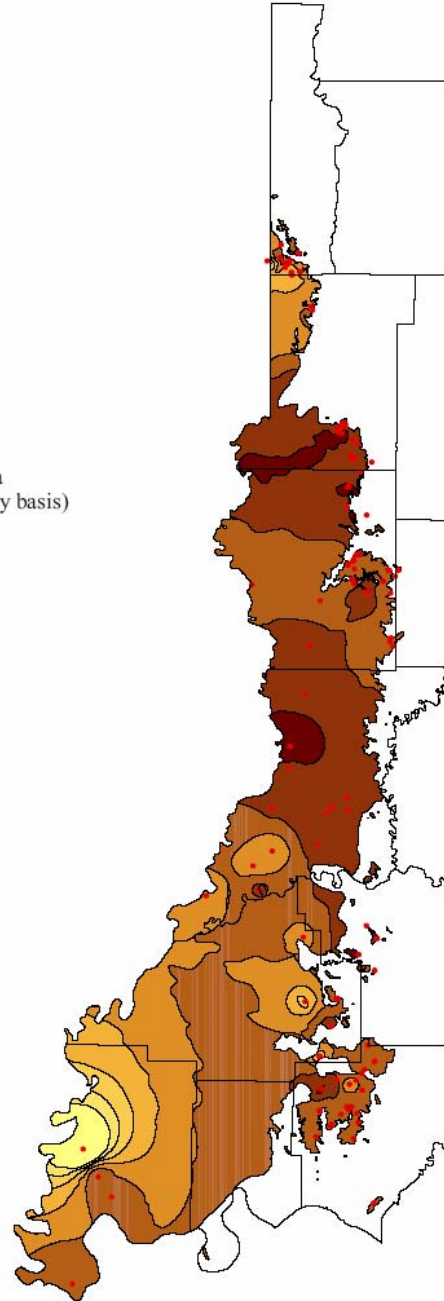
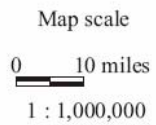
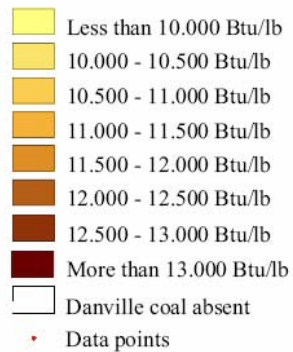

# Task 3:

Identify areas in which more data are needed

Deadline: August 31

10% completed

- Char reactivity
- Slag behavior

- O/C molar ratio
- Fuel ratio (fixed carbon/volatiles)

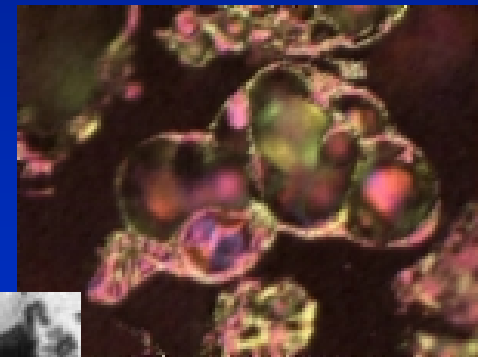

# Next steps:

Tasks	Activity	Deadline	% completed
Task 1	Identifying properties of major importance to IGCC performance of Indiana coals	April 30	100%
Task 2	Assessing availability of data on coal that are critical for IGCC	June 31	100%
Task 3	<b>Identify areas in which more data are needed</b>	August 31	10% / <b>90%</b>
Task 4	<b>Propose new research</b>	<b>November 30</b>	0% / <b>100%</b>

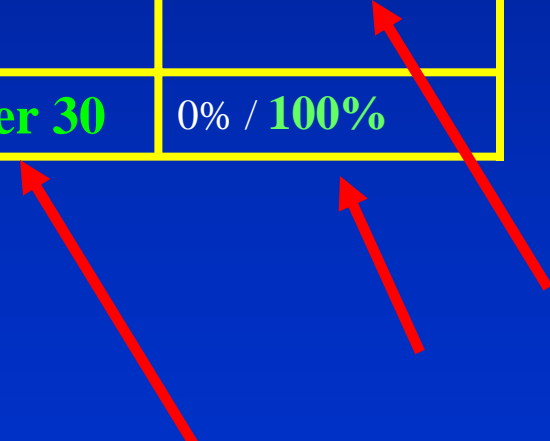

**VISITS:** Wabash River Gasification Plant  
Eastman Gasification Plant – June 14

## **COLLABORATIONS:**

Center for Coal in Sustainable Development (CCSD)– Australian Organization

# INDIANA COAL VERSUS WESTERN COAL?

	Indiana coal	PRB coal
Moisture	10-12% 😊	~28%
<u>Volatile matter</u>	~40%	higher 😊
Heating value	11386 Btu/lb (ar) 😊	Btu/lb 8088 (ar)
Ash content	9.4% (ar)	7.6% (ar) 😊
AFT (flow, Reduction)	Need more data	?
Slag viscosity ~1400°C	Need more data	?
<u>Char reactivity</u>	Very few data Less reactive (higher T needed?)	More reactive because of more volatiles? 😊
Sulfur	3.13% (ar)	0.72% (ar) 😊
Chlorine	0.05%	0.01%

# ACKNOWLEDGMENTS

- Center for Coal Technology Research

